

Aginode Cabling Solutions

INSTALLATION GUIDE FOR OPTICAL FIBRE CABLE

Table of Contents

1.	Foreword	3
2.	Health and Safety Requirements	4
2.1.	Safe Handling	4
2.2.	Materials Safety	4
2.3.	Laser safety	4
2.4.	Bonding	5
2.5.	Important Notes	5
3.	Cable storage and handling	7
4.	Un-reeling rules and recommendations	11
5.	FO cable installation rules and recommendations	14
5.1.	Standard reference	14
5.2.	Intra-building backbone installation	14
5.2.1.	All pathways and spaces	14
5.2.2.	Vertical or Riser	15
5.3.	Inter-building backbone installation	15
5.4.	Pre-terminated OF cables	16
6.	Fibre Optic Cable handling procedures	17
6.1.	Pulling of the Cable	17
6.2.	About Intermediate Pulling	18
6.3.	Jacket Removal	18
6.3.1.	Loose Tube cable structure	19
6.3.2.	Tight Buffer (TB) cable structure	20
6.3.3.	Micro-Bundle (MB) cable structure	20
6.3.4.	ZipCord (ZC) cables	21
6.4.	Core Components	21
6.4.1.	Fibre Stripping	22
6.5.	Pigtail splicing recommendations	24

6.5.1. Tight Buffer versus Maxistrip pigtails	24
6.5.2. Pigtail splicing	26
7. Annex 1: OF cable construction	29
7.1. Fibre	29
7.2. Buffer types.....	29
7.2.1. Tight Buffered Fibre	29
7.2.2. Micro tube Buffered Fibre (Maxistrip).....	30
7.3. Strength Members.....	30
7.4. Ripcords.....	30
7.5. Outer Jacket.....	31
7.5.1. Loose Tube cable structure	31
7.5.2. Tight Buffer cable structure	31
7.5.3. Micro-Bundle cable structure.....	32
8. Annex 2: OF fibre types	33
9. Annex 3: Fibre termination.....	34
9.1. Important note - Inspection, cleaning & testing	38

Important Note: Installation is to be performed by qualified service personnel

1. Foreword

This document forms part of a series of documents related to optical fibre installation. Please see below for further information.

This “Installation Guide For Optical Fibre Cable” document provides information related to key topics that need to be followed during installation.

The following guides provide more detailed information on handling requirements for specific cable types:

- Tight Buffer Cable Supplement
- Loose Tube Cable Supplement
- Micro-Bundle Cable Supplement
- Pre-terminated Cable Supplement

In addition, there is also a General Installation guide (for both copper and fibre) which includes further information.

When logged into the NCS site, all these documents and also others relating to design and installation testing etc can be found [here](#)

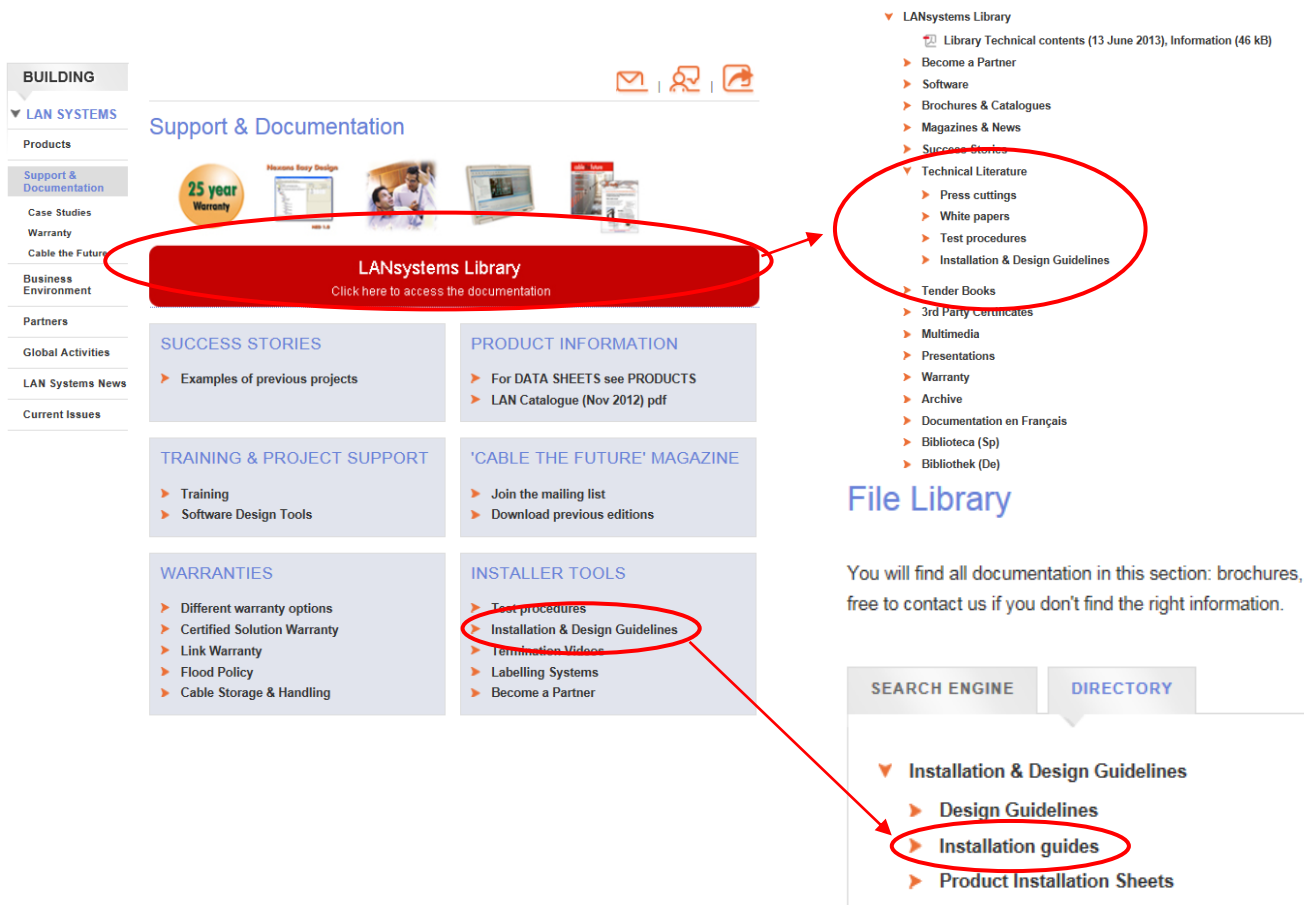

The screenshot shows the LANsystems Library website. A red circle highlights the 'LANsystems Library' button in the 'Support & Documentation' section. Another red circle highlights the 'Installation & Design Guidelines' link in the 'INSTALLER TOOLS' section. A third red circle highlights the 'Installation guides' link in the 'File Library' section. A fourth red circle highlights the 'Installation & Design Guidelines' link in the 'Technical Literature' section of the 'File Library'.

Health and Safety Requirements

2.1. Safe Handling

The broken ends of any fibre and the scraps of fibre created during termination (or splicing) are potentially dangerous so must be handled with care at all times.

The ends are extremely sharp and can easily penetrate your skin or eyes. Once in your skin etc., scraps are almost impossible to find and therefore, their removal is very difficult.

- Do not pick up scrap pieces of fibre by their ends.
- You must properly dispose of all scraps using a dedicated container (as included in the Aginode termination toolkit).
- Do not drop fibre scraps on the floor where they could stick in carpets, shoes or cloths and be later carried elsewhere - including home.
- Never eat or drink anywhere near the work area. Fibre scraps could get into food or drink undetected and be swallowed.

2.2. Materials Safety

Fibre optic stripping, splicing and termination use various chemical cleaners and adhesives as part of the processes.

Correct handling procedures for these substances must be observed.

- If you are not certain of how to deal with them, ask the manufacturer for a MSDS (Material Safety Data Sheet).
- Always work in well-ventilated areas.
- Precautions should be taken to avoid contact with eyes or skin or clothing.
- Even if safe to do so, avoid skin contact as much as possible and immediately stop using chemicals that cause allergic reactions.
- Even simple isopropyl alcohol, used as a cleaner, is flammable and must be handled correctly.
- Smoking should not be permitted in the vicinity of processing chemicals used since this may represent an enhanced hazard due to potential explosion.
- In case of contamination a basic First Aid kit should be available together with a ready supply of water.
- All chemicals should be stored in clearly and correctly marked containers and should be sealed when not in use.

2.3. Laser safety

Under no circumstances should a connector end-face, prepared optical fibre or fractured optical fibre or light sources (LED, VCSEL or LASER) be viewed directly unless the power received from the optical fibre is known to be safe.

Inspection of components shall be done by using a locally injected visible light from a known safe source rather than using light injected from a remote non-controlled location.

Fibre microscopes can be fitted with filters, which greatly reduce the risk of eye damage due to accidental exposure to light from either an operating system or visual fault locator. Always carefully check the presence of such filters (see example below)



Always observe eye safety procedures compliant with your company policy, relevant laser safety standards and safety practice.

Patch Panel adaptors and unplugged connectors should be permanently capped to prevent accidental eye exposure, which might result in injury.

2.4. Bonding

According to EN50174-3 structural metallic elements of cables and cable screens (e.g. armouring or strength members) should be directly connected to earth provided that:

- corrective actions have been implemented for hazards caused by earth potential rise (EPR) between buildings
- any circulating currents, due to potential differences between buildings, will not disturb or damage services

Structural metallic elements of cables and cable screens (e.g. armouring or strength members) shall be treated in accordance with HD 60364-4-444.

Where required, surge protection shall be applied to metallic cable elements in accordance with 4.9.8. of EN50174-3.



Example of cable earthing clip

Relevant national legislation for safe working practices must be complied with.

[Also refer to the Aginode guide to earthing of structured cabling systems available in the White papers section of our web site](#)

*You will need to register before downloading the document
Aginode account creation is a free and quick process.*

2.5. Important Notes

The above are basic safety requirements - your company, regional location or particular installation may specify additional requirements.

The user should ensure that all authorized personnel are aware of the relevant safety issues and shall obtain training where appropriate.



3. Cable storage and handling

Please note: The Aginode warranty may be invalidated if the cables have not been properly stored or handled according to Aginode Cabling Solutions (NCS) requirements.

General storage requirements

- Where reels are supplied with protective material fitted over the cable, the protection should remain in place until the cable is installed.
If the protection is removed prior to installation (for inspection purposes for example) then it must be re-fitted as originally supplied before the reel is placed back in storage or onward shipped.
- Storage temperature range is specified for each cable and must be respected.

Indoor cable storage requirements

- Indoor OF cables are not waterproof and their jacket is not UV resistant.
- Under no circumstances shall any indoor cable boxes or reels be stored outside or in a harsh environment.
- Indoor cables have to be stored in a dry and UV protected location (room or container).
N.B. Watertight containers located outside may suffer from condensation and therefore cannot be assumed to be “dry” or to have low humidity.
- Select a site for storage with no risk of excessive humidity, falling objects, chemical spills (oil, grease, etc.) open flames or excessive heat.
- The data sheet of the cable provides information on temperature ranges for ambient installation and/or operation and/or storage. It is important that those specifications are observed.
- As well as temperature, consideration must be given for moisture as well as other contamination such as flooding.
NCS’s policy on cable exposure to water etc can be found on line: [CLICK HERE](#)
Note: Storing cable on pallets may help to keep cable reels dry in the event of a flood.

Cable handling requirements

- The flanges of reels shall not be interleaved.

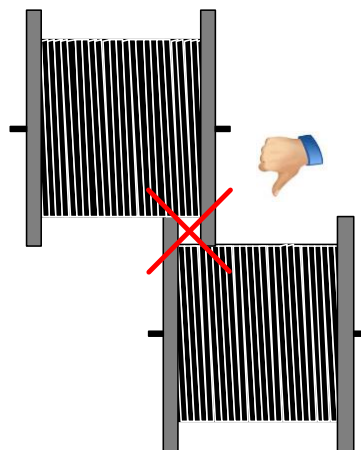

- Reels must not be lifted by their flanges - as below

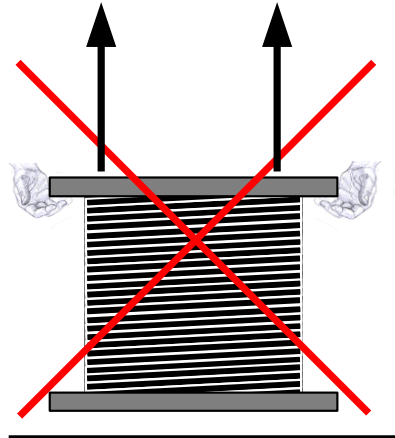

- When it is required to rewind the cable on to another reel, the pulling force applied to the cable must be limited to the maximum pulling force provided on the relevant data sheet for OF cables.
- Should cable be rewound on another reel, the diameter of the new reel shall be compatible with the minimum bending radius of the cable and the original cable label details be copied to the new reel. The new reel shall also be in good condition so as not to cause damage to the cable sheath during the rewinding process.

Outdoor cable storage requirements

- Ends of the cables shall be sealed during storage (heat shrink cable end caps are recommended).
- The data sheet of the cable provides ranges of temperature for ambient installation and/or operation and/or storage. It is important that those specifications are observed.

Recommendations

- All optical fibre reels including part used should be stored upright.

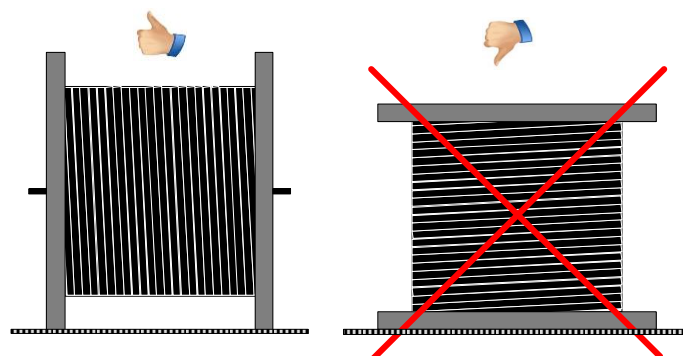

Laying the reel on its side may cause damage to the reel flange and/or cause the OF cable layers to shift - This may cause cable to snag during de-reeling.

- If optical fibre cable is to be stored for longer than approximately four weeks then it is recommended that cable ends are appropriately sealed (heat shrink cable end caps are recommended).
- Reels should be stored in areas with flat firm surfaces.
- Use appropriate devices to secure reels to prevent reel movement during storage.
- Avoid storage areas that are susceptible to flooding, or that could damage the cable, such as sharp, uneven terrain.
- When rolling / moving reels do not “kick” the cables. Ensure that the route has no objects or uneven terrain that could damage the cable when the reel is being rolled.

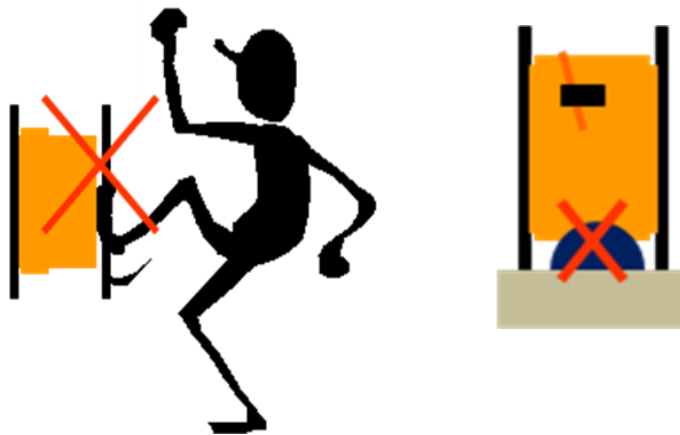

- Where it is necessary to lift reels and the cable reel is too heavy to move manually, the reel must be moved upright by lifting the cable with a fork lift or reel mover. The forks must be placed under the reel with the forks always perpendicular to the reel flange.

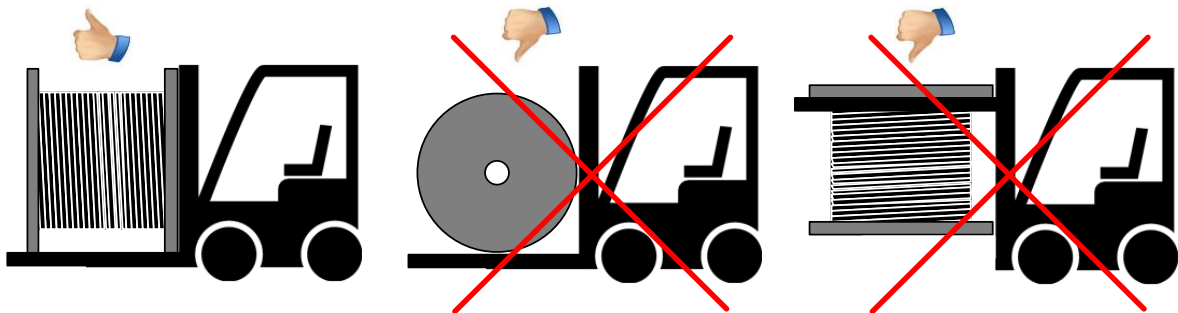

- Never drop a cable reel from any height during transportation or use. Dropping a reel could affect its structural integrity and cause de-reeling issues – it may also damage the product. When unloading from a vehicle, use either the tail-lift / elevator (if fitted) or a suitable mechanical aid such as a forklift truck. Never let reels drop from the vehicle to the ground.

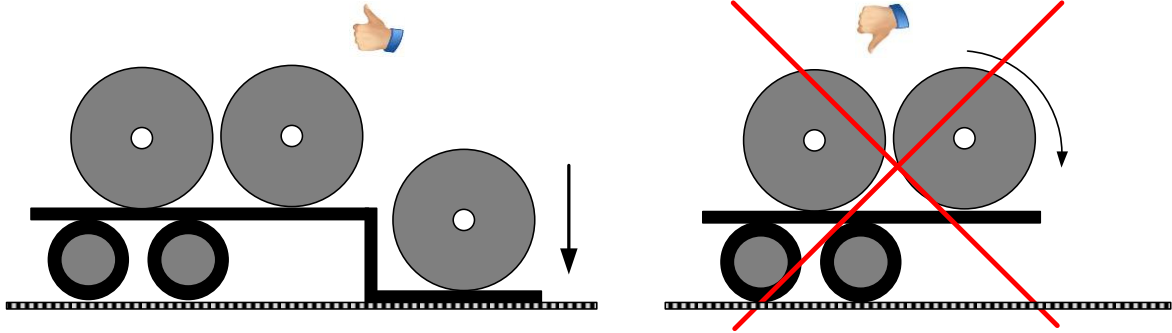

- Before de-reeling cable, the reel should be visually inspected for possible damage caused during storage.
- It is recommended to record the data provided on the labelling tags of all the drums/reels/boxes in case of any subsequent issues.
- Aginode recommend that cable reels should be stored in a safe, locked location.

Health & Safety

When manually handling a reel, ALWAYS make sure correct manual handling techniques are used and that consideration to mechanical lifting aids is given.

General

Where local requirements for cable storage & handling and/or Health & Safety are more stringent than the above, those requirements must also be followed.

4. Un-reeling rules and recommendations

Before laying the different cable sections, all reels should be visually inspected for possible transportation damage.

Inspect every cable reel for damage and be particularly alert for cable damage if :

- A reel is laying flat on its side
- Several reels are stacked
- Other freight is stacked on a reel
- Nails have been driven into reel flanges to secure shipping
- A flange of the reel is damage
- The reel protective covering is removed or damaged
- A cable end seal is removed or damaged

Remove all nails and staples from the reel flanges before moving a reel, and avoid all objects that could crush, gouge or impact cables when moving the reel. NEVER use the cable as means to move a reel.

The installer should ensure that all necessary guards, protective structures and warning signs are used to protect both the optical cable and third parties.

Relevant national legislation for safe working practices must be complied with.

Never install a fibre optic cable if temperature is below -5°C (HDPE jacket) or below 0° (LSZH jacket). Be aware that in cold environment the cable jackets are stiffer and more sensitive to bending and pulling. The range of recommended installation temperatures of cables is much smaller than the operating temperature ranges.

Refer to the cable data sheet - see example below

If air temperature at the cable storage location will be below 0°C the cable shall be moved to a heated location for 24 hours before installation - ideally around 20°C.

Maintain the minimum bend radius and manually feed cable around bends. While pulling the cable use the 'Dynamic bending radius' figure because the cable is under tension.

Refer to the cable data sheet - see example below

Usage characteristics	
Minimum dynamic operating bending radius	210.0mm
Minimum static operating bending radius	150mm
Ambient installation temperature, range	0 .. 40°C
Operating temperature, range	-20 .. 60°C
Storage temperature, range	-30 .. 60°C

Observe tensile load. The maximum allowed pulling force shall be respected during the installation process. During operation the permanent force shall be limited to the value specified on the data sheet. Refer to the cable data sheet - see example below

Mechanical characteristics	
Maximum pulling force (IEC 60794-1-2-E1)	1500N
Maximum operating pulling force	450N



For safety reasons, always un-reel the cable by the bottom side of the reel. In that case the reel will roll away from the workers if it escapes from the support.

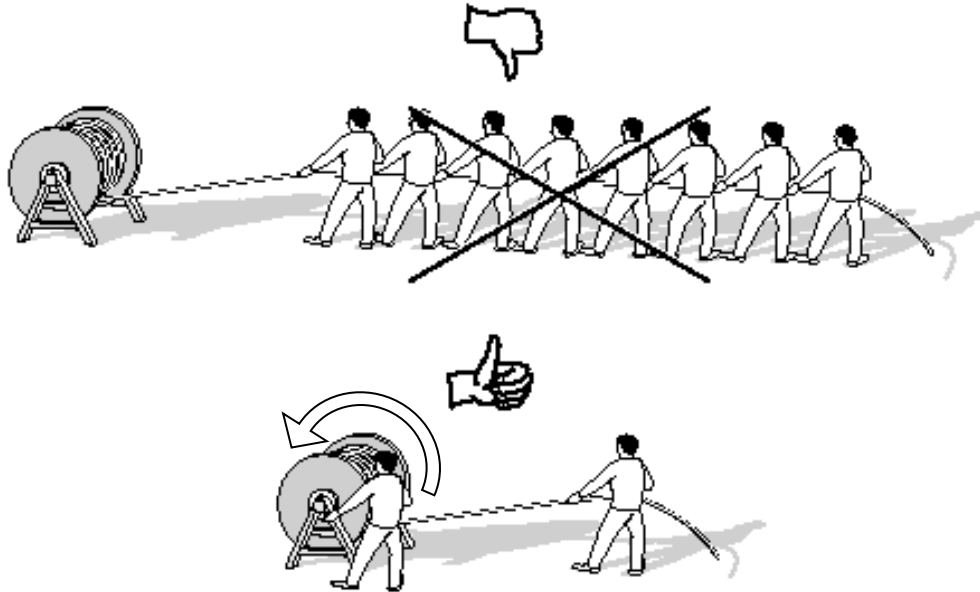

Pulling directly on the outer jacket with an excessive force will cause a compression of the fibre and create significant loss increase. The condition once initiated is usually irreversible.
Refer to the chapter 5: OF cable handling procedure

Other recommendations

- Poles used to support drums should be as large as possible
- Cable shall be reeled off the drum and not be spun over the edge of the drum, so as to avoid cable twist
- Ensure cable sheath is not damaged on drum edges or has any tears or burns
- Ensure cables lie within pathways
- Ensure all sharp edges are protected PRIOR to cable installation

5. FO cable installation rules and recommendations

5.1. Standard reference

Rules and recommendations for OF cable installation are important.

Please refer to the **EN 50290-4-2 standard: Communication cables - Part 4-2: General considerations for the use of cables - Guide to use**

In particular you will find very useful information in the chapter 7 (installation practices) and chapter 8 (cabling installation versus location)

5.2. Intra-building backbone installation

Inside a building, it is strongly recommended to select a cable compliant to both the IEC 60332-1 (flame retardant) and IEC 60332-3 (fire retardant) standards.

Those cables have a LSZH-FR jacket (a major part of our Aginode Cabling Solutions indoor and indoor/outdoor cables are made using a LSZH-FR jacket material).

Vertical installation of Loose Tube cables is not recommended. Tight Buffer cables or Micro-Bundle cables are preferred for vertical installation.

In case of vertical installation of Loose Tube cables, loops in the cable shall be created approximately every 10 metres to reduce the jelly drainage effect (jelly moving down the tube over time towards the low end) and fibre creep due to the load created by its own weight.

Note: specific cable constructions compliant to the IEC 60331-25 standard (fire resistant) are also available on request.

5.2.1. All pathways and spaces

In order to avoid crushing and stressing the FO cables shall never be laid under copper cables.

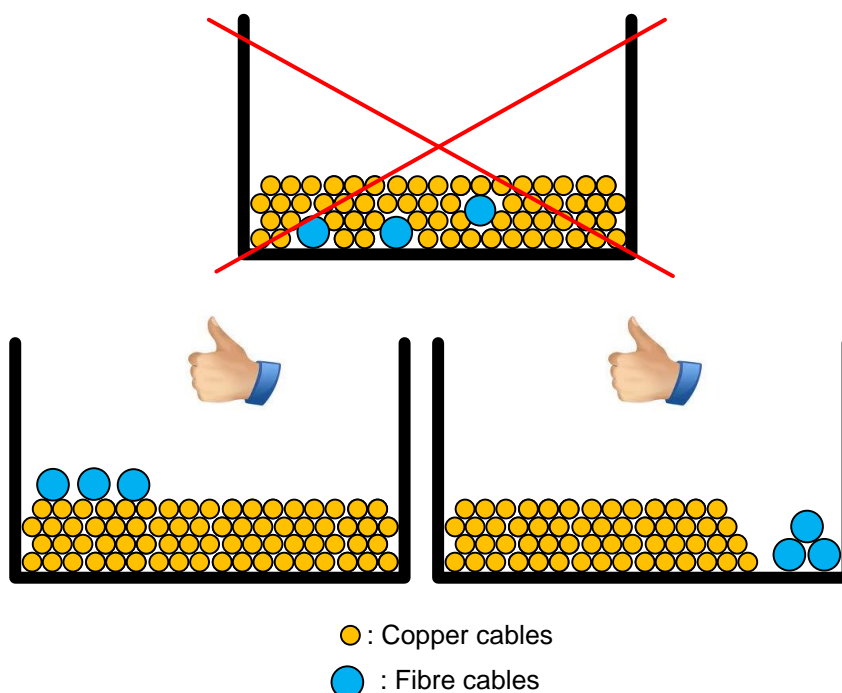

5.2.2. Vertical or Riser

While installing fibre cables in vertical shafts or risers we recommend creating two loops of cable every 10 to 15 metres. The diameters of the loops shall take into account the minimum bending radius of the cable. This recommendation is valid for all cable constructions.

Directly pulling on the cable can generate tension load and/or crushing loads which will cause damage. Split wire mesh grips (cable pulling grip) work like basket or finger grips, supporting the cable without crushing the core during installation.



It is recommended to feed cable down risers as it will obviously be easier to install the cable - allowing the weight of the cable to help rather than adding more pulling load.

Cables should be permanently supported by cable ties, straps or clamps all along the path in the riser to reduce the permanent tensile load and avoid any damage.

5.3. Inter-building backbone installation

Important Note

Loose Tube cable constructions having a Polyethylene (PE) external jacket shall be selected for direct burial installation.

Armoured cables are rodent resistant. The armour can be made of corrugated steel (UC / MC constructions) or FRP (Fibre Reinforced Plastic) (UD / MD structures).



LANmark UC structure



LANmark UD structure

Note: Conduit diameter must be at least 2 times the fibre optic cable diameter.

There are two different ways to install fibre optic cable into pathway

Cable pulling

For more information concerning cable pulling, please refer to the next chapter “Fibre Optic Cable handling procedures - Pulling Cable”.

Cable blowing is another way to install cable in pathway.

The method is based on 2 principles:

- An effect of mechanical pushing force of the micro cable generated by the blowing machine
- A lift effect of the micro cable due to the circulation of the air at high speed in the micro duct

This is a specific installation method, which requires the use of specific and expensive material. This method has to be performed by qualified service personnel. The description of the cable blowing procedures is outside the scope of this document.

Aerial installation requires the use of cables especially designed for aerial installation and the use of specific accessories and equipment to be used by persons having the required technical skill. This type of installation is not usual in LAN applications and is so outside the scope of the present document.

However, inter-backbone links installation can require aerial installation of short runs of fibre cable.

In this case an external support member will be first positioned between the buildings. Poles could also be required. The fibre cable will then be tied to the support member.

The support member or catenary has to be selected according to its size, its tensile strength and the span distance to be covered.

The complete description of this process is not in the scope of this general installation guide document.

5.4. Pre-terminated OF cables

The Pre-terminated Cable Handling Guide Supplement provides information related to key topics that need to be followed during installation.



LC/SC pre-terminated assemblies



MPO/MTP trunk

6. Fibre Optic Cable handling procedures

Specific cable handling guides developed for the various Aginode cable constructions are available.

These documents describe the procedures to correctly pull-in those cables and how to strip the cable jackets.

Installers are required to take these procedures into account when installing Aginode OF cables. Aginode will be unable to accept claims if the rules described in current general guide and the specific procedures have not been fully respected.

6.1. Pulling of the Cable

Important note

In any fibre optic cable the load has be applied to the strength members of the cable. Failure to lock the cable components together can lead to elongation of the jacket material which when released will cause irreparable damage to the fibres resulting in significant performance degradation.

Please refer to the specific Aginode cable handling guide of the cable structure to be installed for detailed information.

Fix the cable to the pulling rope / tape using a specially designed pulling grip for optical fibre cable (length of 600mm minimum) to ensure that the pulling tension is well distributed on all cable components (outer sheath and reinforcing elements).



Pulling grips

A swivel shall be installed between the pulling rope and the pulling grip to prevent the pulling rope (pull-line) from imparting a twist to the cable.



Swivel

It is also important to monitor the tension being applied to the cable (by the pulling device / winch) to be certain not to exceed the maximum specified cable installation load.

Maintenance of the minimum bending radius of the cable is also required.

Proper pulling guides (cable bending shoes, sheaves, ..) shall be installed especially at the pull end. These guides are to ensure that the cable exits the duct and the maintenance hole opening in the correct way. In particular the cable shall never rub against any fixed object during the pulling operation.

If cable pulling lubricant is introduced as a means of lowering pulling tension it is important to ensure that the selected product is appropriate and will not deteriorate the Polyethylene (PE) or LSZH sheath. In particular LSZH sheath requires the use of specific lubricant. Refer to the lubricant manufacturer's specifications.

Before termination, approximately 3m of cable should be cut off to remove any piece that may have suffered stress from the pulling tape or grip.

6.2. About Intermediate Pulling

In many installations the distance to be covered is short and the path is straight enough to allow the cable to be easily pulled (with a pulling grip correctly installed onto the cable end) without the need for intermediate pulling.

However, on longer runs it may be necessary to pull the cable at intermediate points if the pulling force to be applied on the cable to pull it in one go through the duct, would exceed the max pulling force allowed by the manufacturer.

Please refer to the specific Aginode cable handling guide of the cable structure to be installed for detailed information.

Important note about Tight Buffer (TB) and Micro-Bundle (MB) cable structures

NEVER grab the outer sheath (jacket) of a TB or MB cable when trying to pull cable out of a duct. If a cable is grabbed by hand, the point pressure that is applied in this manner may cause the outer sheath to be elongated as well as causing the fibres to be stretched.

When the cable is then released, the optical fibres will then pull back and bunch up within the cable structure, which will cause irreparable damage to the fibres resulting in significant performance degradation.

In any fibre optic cable, it is imperative that the load be applied to the strength members of the cable.

6.3. Jacket Removal

For any fibre count or cable type, some amount of the cable outer jacket will have to be removed to expose the fibres for the termination process.

For simplex or duplex cables whose jackets are designed to fit within the connector, the length of jacket removed will be specified by the connector requirements.

Typical figure for outer jacket removal for these cables is 4 to 5 cm.

Multi-fibre cables will need longer lengths of the jacket removed.

Outside plant cables that will be terminated in trays may need over 2 metres of jacket to be removed.

Recommended lengths are provided in the Aginode patch panel installation guides

Outer jacket stripping tool

Various cable strippers can be used to remove the outer jacket of an OF cable. Aginode recommend the use of the following specific tools:

6.3.1. Loose Tube cable structure

The recommended tool is designed to cut the jacket longitudinally and around as shown below.

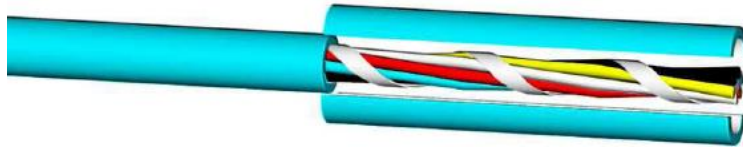

The stripping tool shall be set according to the diameter of the cable to avoid any damage of the tubes containing the fibres.



Loose Tube cable stripping tools

For detailed information please refer to the specific Aginode handling guide for Loose Tube cable structure.

Please note that Aginode Cabling Solutions sells this recommended tool.

6.3.2. Tight Buffer (TB) cable structure

Distribution cable jackets can be removed using round cable slitters or other tools that will not damage the interior of the cable.

The Aginode recommended tool adapted to TB cable structure is designed to cut the jacket longitudinally and around.



OGCL stripping tool

For detailed information please refer to the specific Aginode handling guide for Tight Buffer cable structure.

Please note that Aginode Cabling Solutions sells this recommended tool.

6.3.3. Micro-Bundle (MB) cable structure

The OGCL tool (see chapter 5.3.2) is also recommended to strip the jacket of the Micro-Bundle cables.

The MB fibres are contained in an advanced flexible LSZH tube having a diameter of 1.3mm. It can be stripped using the following tool.



For detailed information please refer to the specific Aginode handling guide for Micro-Bundle cable structure.
Please note that Aginode Cabling Solutions sells this recommended tool.

6.3.4. ZipCord (ZC) cables

Simplex and duplex cable jackets are usually removed no more than a few centimeters from the point of termination and are easily taken off using standard buffer or jacket strippers.

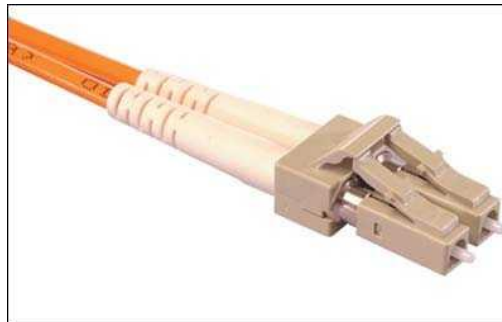

6.4. Core Components

After the jacket has been removed to the required location, the ripcord can be cut back to the jacket.

In cables that have layers of aramid in the core (patch or distribution style) trim the aramid (or glass) yarn to the necessary length as specified by the equipment or connector requirements. Aramid is more easily cut by scissors sold specifically for this purpose.



Central strength members also need to be trimmed. Some are cut back to the jacket so they will not interfere with termination, other applications will call for the central strength member to be

cut to a specific length and incorporated in termination (i.e. some break-out kits). Central strength members made with fibre glass rod can be cut using almost any cutting tool.

Buffer tubes on Loose Tube cables are easily removed. Buffer tube cutters are designed specifically for this purpose. Cable strippers can be used.



Although not recommended it can also be done with a knife or a cutter if this is the only option available. Carefully score one side of the tube with the knife (not too deeply to avoid damaging the fibres) and bend the tube away from score.

The separated piece of tube can be pulled off the end of the fibre.

Micro-Bundle cables: the fibres are contained in an advanced flexible LSZH tube having a diameter of 1.3mm. It can be stripped using the following tool.



Loose Tube and Micro-Bundle cables tubes are jelly filled. The fibres shall be carefully cleaned using an appropriate degreaser before termination.

For detailed information please refer to the specific Aginode cable supplements for Loose Tube and Micro-Bundle cable structures.

6.4.1. Fibre Stripping

There are varieties of commercially available tools that will strip the buffer and coating of 900 μm (0.9mm) tight-buffered fibres or the 250 μm (0.25 mm) coating of the maxistrip fibres.

Note: μm = micron - e.g. 900 μm = 0.9mm

Tight buffered fibres can be stripped either in a one-step or two-step process. Tools sold for one-step removal will take off the buffer and coating in one action (to strip from 900 to 125 μm in one go).

The two-step procedure requires one tool to remove the buffer (to strip from 900 to 250 μm), and one for the coating (to strip from 250 to 125 μm). Taking the coating off maxistrip fibres can be done with the same tool used for tight-buffered fibres, or with specific tools that can be preset for either function or having the blades exchanged for the two functions.

The amount of buffer and/or coating removed will depend on the application and termination procedure. Many connectors will come with exact templates for this purpose. See the hardware or connector specific instructions.



Fibre coating Stripping tool

6.5. Pigtail splicing recommendations

6.5.1. Tight Buffer versus Maxistrip pigtails

- A. Two types of pigtails are available in the Aginode range
- Tight Buffer
 - Maxistrip

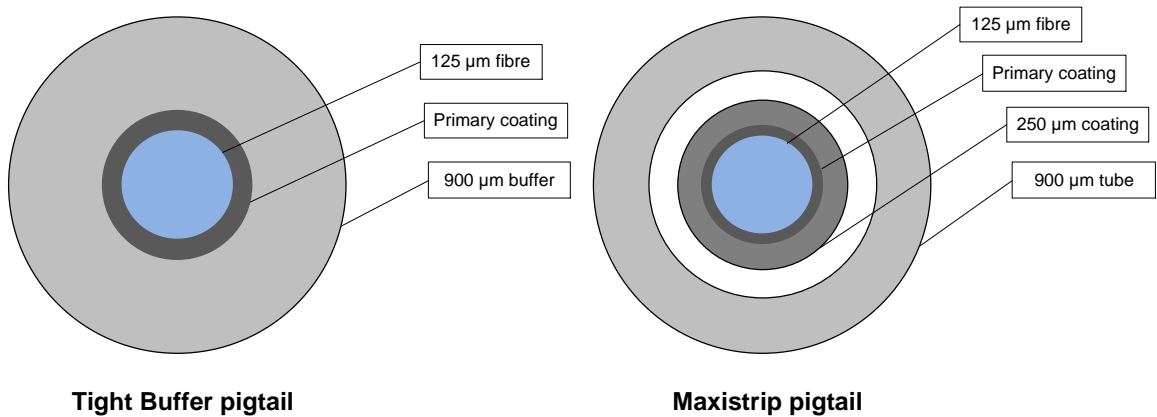

The 900µm coating of the Tight Buffer pigtail can be stripped in one action over a distance of 1-2 cm exposing the bare fibre while the coating of the Maxistrip pigtail can be stripped in one action over a distance of up to 1m exposing the 250µm coated fibre (which is loose inside the 900 µm micro tube).

Important note

We recommend splicing Tight Buffer pigtails on Tight Buffer cables and Maxistrip pigtails on Loose Tube or Micro-Bundle cables to avoid mixing 250µm and 900µm coated fibres together on the same splice tray.

When splicing Tight Buffer pigtails (900 µm coated) on 250µm coated fibres (Loose Tube or Micro-Bundle structures) or when splicing Maxistrip pigtails on Tight Buffer cables the additional stress on the 250µm coated fibres shall be limited to avoid any loss increase.

- B. Two types of splice protectors are available in the Aginode range
- Heat shrink
 - Aluminium



Heat shrink protectors



Aluminium protectors

Heat shrink protection is compatible with both 250 μm and 900 μm coated fibres and can be used for all cable structures: Tight Buffer, Loose Tube and Micro-Bundle. As such they can be used on both Tight Buffer and Maxistrip pigtails.

Aluminium protection is only compatible with 250 μm coated fibres and can only be used for Loose Tube and Micro-Bundle cable structures. It is NOT compatible with the 900 μm coated fibre of Tight Buffer cable and pigtail structure. As such they can only be used with Maxistrip pigtails.

Note

- The size of the Aluminium splice protection is smaller than the heat shrink version
- The use of a crimp tool is required to install the aluminium splice protectors



C. Two types of splice cassettes are available in the Aginode range

- for **12 x** heat shrink protectors
- for **24 x** aluminium protectors



12 x heat shrink protectors

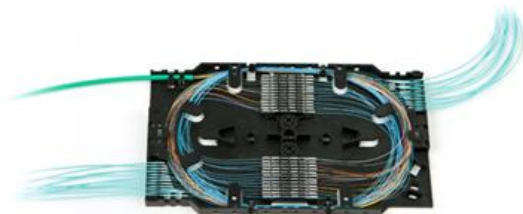

24 x aluminium protectors

Four trays can be stacked inside the fibre patch panels resulting in a maximum capacity of

- 48 fusion splices using heat shrink protectors
- 96 fusion splices using aluminium protectors

As such heat shrink protectors can be used with the following pre-loaded patch panels:

- 24 LC
- 48 LC
- 48 SC

Therefore, aluminium splice cassettes with Maxistrip pigtails are to be used for 96 LC LANmark-OF preloaded patch panels.



6.5.2. Pigtail splicing

Preliminary Note

The following recommendations do not explain the complete pigtail splicing process and have to be considered as a supplement to the complete set of instructions provided by the manufacturer of your splicing machine.

The stripping of the Maxistrip pigtail and its installation into the splicing machine requires more attention.

A. Tight Buffer pigtail splicing recommendations

Note: Do not forget to slide a heat-shrink splice protection sleeve on one of the fibres prior to fibre preparation for splicing.

Only small length of the 900 μm buffer can be removed at a time (1-2 cm) using a fibre coating stripping tool (see 6.4.1).

Strip the desired length of fibre (+/- 40mm) according to the requirements of your fibre cleaver.

The fibres shall be carefully cleaned using an appropriate degreaser before termination.

Cleave the fibre and install the end of the Tight Buffer pigtail into the guides of your splicing machine.

You must clamp the Tight Buffer pigtail into the guides on its 900 μ m buffer coating.



B. Maxistrip pigtail splicing recommendations

The Maxistrip pigtails can be stripped in one action over a distance of up to 1m exposing the 250 μ m coated fibre as it is a Loose Tube construction in which one 250 μ m coated fibre is installed.

First strip the 900 μ m loose buffer on the entire length of fibre that will be needed on the splice tray (the length could be of 30 to 50 cm depending on the size of the splice tray and the fibre arrangement on the tray). The 900 μ m buffer shall be stripped back to the pigtail retaining part of the tray as circled below.

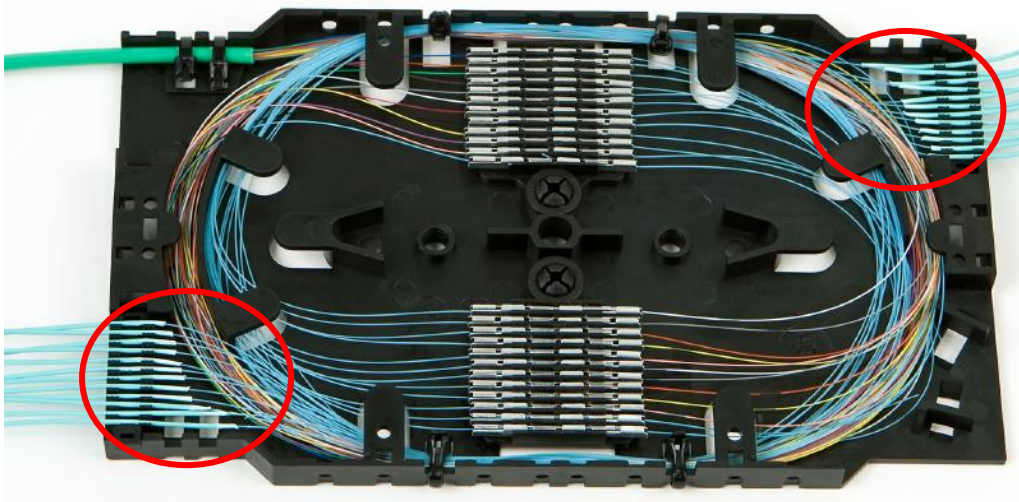

Only 250 μ m coated fibre shall be arranged on the splice tray.

Then strip the 250 μ m coating to the desired length (+/- 40mm) according to the requirements of your fibre cleaver.
The fibres shall be carefully cleaned using an appropriate degreaser before termination.
Cleave the fibre and install the end of the Maxistrip pigtail into the guides of your splicing machine.

You must clamp the Maxistrip pigtail on its 250 μ m buffer coating.

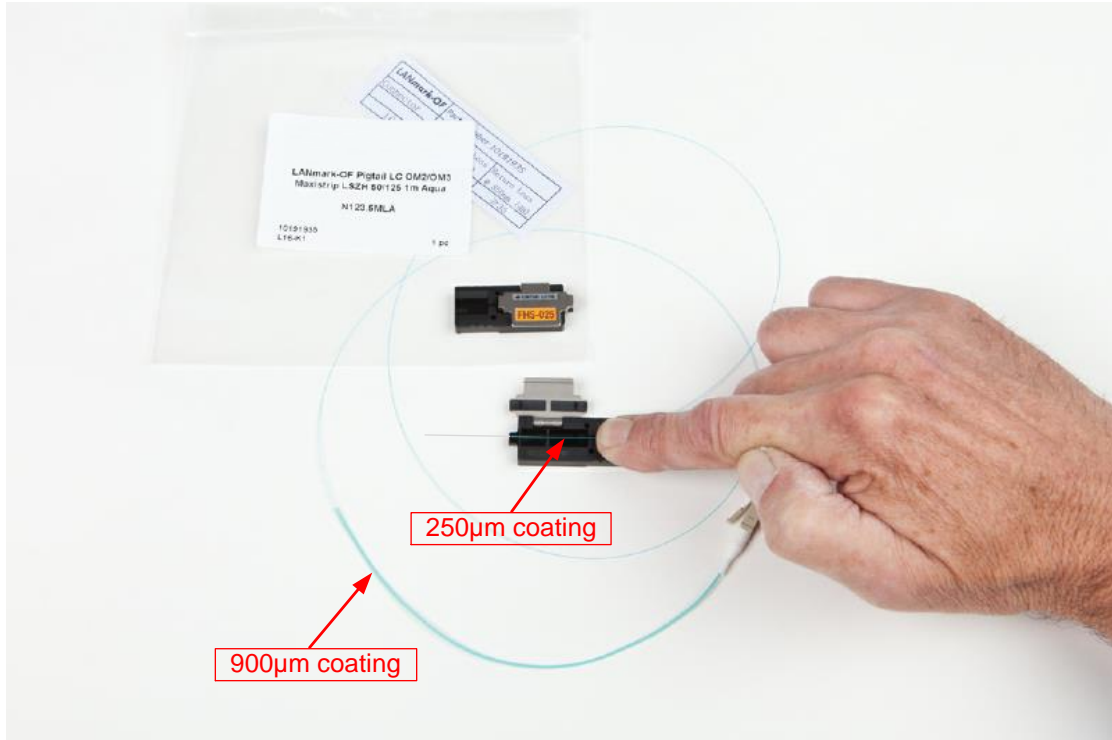

Never clamp the Maxistrip fibre on its 900 μ m coating. If you do so the fibre will remain loose into the coating and will move during the splicing process. As a consequence the splice will not be successful.

7. Annex 1: OF cable construction

A basic knowledge of fibre and cable design is required to understand how to correctly handle optical fibre cable.

Eliminating confusion between the different terms, and providing an understanding of the cable construction will make the products handling less complicated.

7.1. Fibre

Aginode takes coated optical fibre and incorporates it into a multitude of finished cable products.

All of the glass fibre used by Aginode is manufactured using the same basic construction. Two layers of glass are covered by a protective coating.

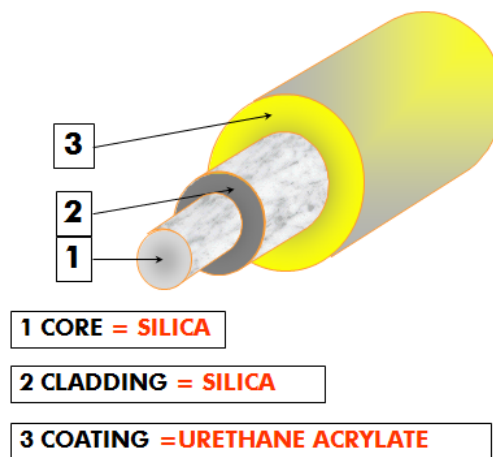

The core and cladding of the fibre are both made of glass. These two layers propagate the light signal and determine the performance of the fibre. A slight difference in optical characteristics between these two layers keeps the signal within the core region.

The glass is protected by a dual layer of ultra-violet-cured acrylate material. The coating protects the surface of the glass from abrasion during normal routine handling, thereby ensuring the glass maintains its high tensile strength. The acrylate coating, which also functions optically by stripping out any light which might enter the cladding region, is removed for termination and splicing.

7.2. Buffer types

All of Aginode Cabling Solutions fibre optic cables fall into one of 2 categories: tight buffered or micro tube buffered.

7.2.1. Tight Buffered Fibre

A thermoplastic material is extruded directly over the acrylate primary coating, increasing the outside diameter of the fibre to 900 micron (0.9 mm), an industry standard. The Tight Buffer supplies the fibre with added mechanical and environmental protection, increased size for easy handling, and a simple means of adding colour coding for fibre identification. During the termination process, the buffer is stripped back to an exact length as stipulated by the connector termination requirements.

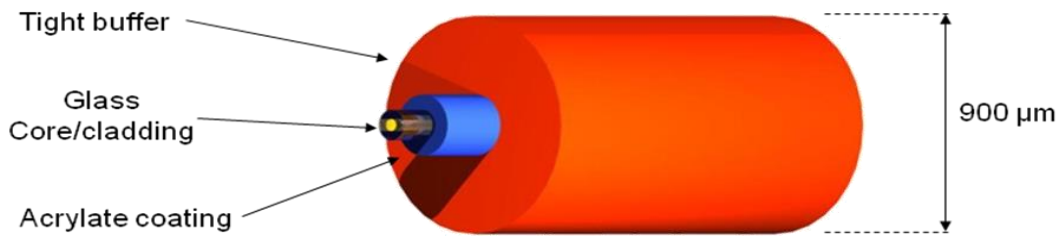

7.2.2. Micro tube Buffered Fibre (Maxistrip)

The fibre at 250 micron is loose inside a micro tube. Outside diameter of this micro tube is 900 micron (0.9 mm), an industry standard. The micro tube supplies the fibre with added mechanical and environmental protection, increased size for easy handling, and a simple means of adding colour coding for fibre identification. During the termination process, the micro tube is easily stripped back to an exact length as stipulated by the connector termination requirements. The big advantage of this product (in comparison with Tight Buffer) is that you can easily strip up to 1m in one go.

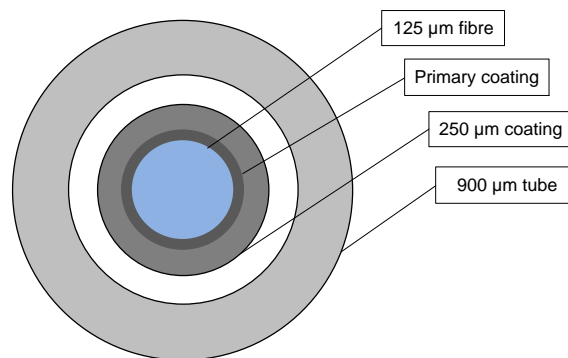

Maxistrip fibre

7.3. Strength Members

Aginode Cabling Solution’s optical fibre cable designs utilise glass yarn as the primary strength member (aramid yarns are also used in some cable designs like patch cables and TB cables). Some designs also use a fibre glass central strength member. These materials serve as the load bearing members of an optical fibre cable during installation. In patch cables the aramid yarns also act as a strength member during the termination process. The following picture is showing a single fibre cable, where the tight-buffered fibre is surrounded by aramid and coated with an overall jacket.



7.4. Ripcords

Ripcords are designed to make removal of the outer cable sheath easier, preventing unnecessary stress to the core. Ripcords provide a means of stripping back the jacket without

the use of invasive tools, which could harm the cable core and damage fibres if incorrectly used.

The rip cord is visible on the lower side of the following cable picture.



7.5. Outer Jacket

The true cable jacket is usually the outermost element in the cable design. It serves to protect the cable against environmental hazards and gives the installer a means of managing the cable.

Typical jacket materials include Polyethylene (PE) or LSZH-FR material.

Pay attention to local requirements regarding the maximum amount of PE jacketed cable that is allowed to be installed within buildings.

7.5.1. Loose Tube cable structure

In Loose Tube cables, the coated fibre "floats" within a sturdy, abrasion resistant, oversized tube which is filled with optical jelly. Since the tube does not have direct contact with the fibres, any cable material expansion or stress placed on the tube (within the handling / installation specification of the cable) will not affect the fibre.

Much of the external stress placed on the tube also will not be transferred to the fibre.

The non-hygroscopic jelly prevents water from entering the tube. The latter has a capacity of 4 up to 24 fibres.

The central Loose Tube is reinforced with watertight glass yarns and with an armour (dielectric or corrugated steel) providing excellent mechanical resistance and rodent resistance

The external jacket is waterproof HDPE and UV resistant.

This structure is adapted for outdoor use in duct and can also be directly buried in the ground.



7.5.2. Tight Buffer cable structure

The cable is a dry construction i.e. with no jelly content.

Every fibre is 900µm secondary coated.

The cable strength member is water resistant glass yarn laid longitudinally between the fibres and the inside wall of the LSZH UV resistant outer jacket.

A central strength element is the core of the cable and is used when pulling cables in a duct. This optical fibre cable shall be used for indoor installations and for outdoor duct applications having short runs - as intermediate pulling is restricted.

This cable shall be selected where the required fibre count is from 4 to 24.

The TB cable is suitable for connector manufacturer field termination processes (SC or LC connectors) and for OF pigtails splicing.



7.5.3. Micro-Bundle cable structure

Every fibre of this cable structure is 250µm diameter secondary coated.

The fibres are contained in an advanced flexible LSZH micro- tube having a diameter of 1.3mm.

The tubes containing up to 12 fibres filled with a small amount of jelly.

With a maximum of 8 Micro-tubes around the glass yarn central strength element the cable can contain up to 96 fibres for a diameter equivalent to the one of a 24 core Tight Buffer structure.

The Micro-tubes are protected with reinforced aramid yarns. The jacket material is LSZH. Since there is no drip effect the very limited amount of jelly in the cable construction, the cable is optimised for both horizontal and vertical installations.

This optical fibre cable shall be used for indoor installations and for outdoor duct applications having short runs - as intermediate pulling is restricted.



8. Annex 2: OF fibre types

The complete description of optical fibre transmission is too complex to be described in the current document but a few key points should provide some helpful information.

Two main types of glass fibres can be use for LAN data transmission Multimode (MM) and Singlemode (SM) fibre.

Multimode fibres have a larger core (62.5 or 50µm) while Singlemode fibre have a smaller core size (9µm). Both MM and SM fibres have an external diameter of 125µm.

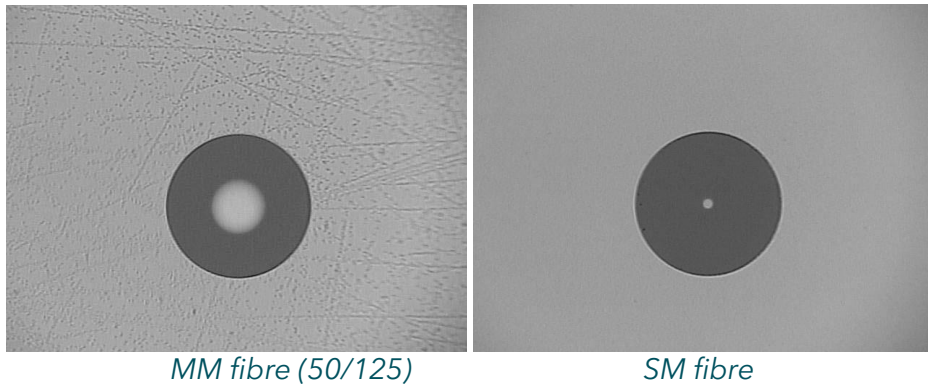

The cabling system standard (ISO 11801) defines 5 different types of fibres:

- OM1 ≈ Legacy 62.5/125* (no longer recommended)
- OM2 ≈ Legacy 50/125*
- OM3 ≈ Recommended 50/125
- OM4 ≈ Extended reach 50/125 for 10/40/100Gbps
- OS1 ≈ Singlemode G652 A or B / IEC 60793-2-50 fibre type B1.1 (1310 nm & 1550 nm only)
- OS2 ≈ Singlemode G652 C or D / IEC 60793-2-50 fibre type B1.3 (1310 nm, 1550 nm and 1383 nm - low water peak - CWDM operation)

Note: All Aginode SM cables pigtails and patch cords are now produced by default with OS2 fibres.

The fibre to be selected is defined according to the following tables providing the maximum length allowed in support of the application to be transmitted over the fibre.

@840nm		Fibre type			
		LAN mark-OF1 OM1	LAN mark-OF2 OM2	LAN mark-OF3 OM3	LAN mark-OF4 OM4
Application	100 BASE-SX	412m	412m	412m	412m
	1Gbit SX	275m	550m	880m	900m
	10Gbit SR	33m	82m	330m	550m
	40Gbit SR4			100m	150m *
	100Gbit SR10			100m	150m *

@1300nm		Fibre type				
		LAN mark-OF1 OM1	LAN mark-OF2 OM2	LAN mark-OF3 OM3	LAN mark-OF4 OM4	LAN mark-OFsm OS2
Application	100 BASE-FX	2,000m	2,000m	2,000m	2,000m	2,000m
	1Gbit LX	550m	550m	550m	550m	5,000m
	10Gbit LR/LW	-	-	-	-	10,000m

9. Annex 3: Fibre termination

Fibre termination is a matter for specialists and will not be fully described in this document.

Connection of optical fibres is a process requiring high precision. As the light signal is transmitted over the core of the fibre a perfect alignment of the very small fibre cores is required to avoid high loss in the connection.

There are two different ways to connect optical fibres together.

Optical fibers can be permanently spliced together using a fusion splicer or a mechanical splice. Splicing fibres is the best way to obtain a very low loss connection but

- The connection is permanent - No disconnection / reconnection possible
- Fusion splicing requires the use of expensive splicing machines able to align the two fibres with a high degree of precision.



Samples of splicing machines

Secondly connectors can be installed onto the fibre to allow disconnection and reconnection. The loss using connectors is always higher than the loss of a splice but has the advantage of not being permanent.

Connectors can be field terminated using various methods. Aginode recommends the use of anaerobic connectors. A complete set of tools and consumable for anaerobic connector termination is available in our range.

The first picture below is showing a patch panel including the pigtails spliced with the fibres of cables and protected in splice trays. The second one shows the arrangement of splices within the splice trays.

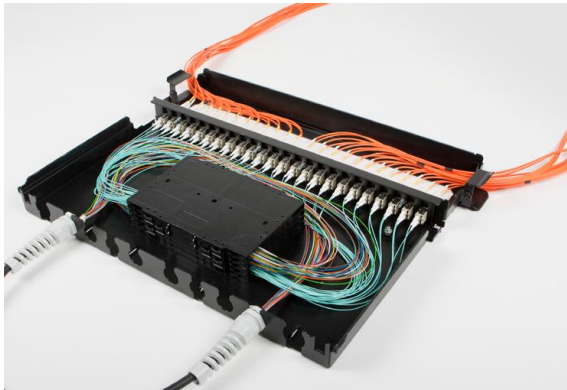

Type of optical fibre connectors

There are three main types of connectors ST, SC and LC.

ST connector is the oldest one. Belonging to a former generation of connector types, it is no longer recommended due to the potential inconsistency of loss levels achieved.



Dual ST patch cord

SC and LC connectors are the ones currently in use, the advantage of the LC being its smaller size.



Dual SC patch cord



Dual LC patch cord

As shown on the drawing bellow the same OF patch panel can be equipped with twice as many LC connectors due to its smaller size.



LANmark-OF PRE-LOADED 96LC FRONT PANEL LAYOUT



LANmark-OF PRE-LOADED 48LC FRONT PANEL LAYOUT



LANmark-OF PRE-LOADED 48SC FRONT PANEL LAYOUT



LANmark-OF PRE-LOADED 24SC FRONT PANEL LAYOUT

MPO / MTP connectors

MPO/MTP connector is a specific multi-fibre (12 or 24 fibres) connector now becoming the standard for 40/100Gigabit Ethernet applications requiring the use of parallel optics technology for transmission over multimode fibres.



MPO connectors are usually factory pre-assembled.

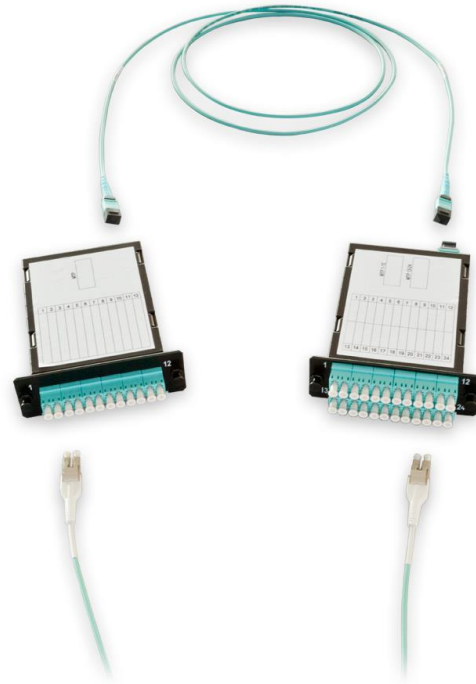

9.1. Important note - Inspection, cleaning & testing

The cleaning of all the optical fibre connectors prior to the installation (pigtail, patch cords etc) is a critical factor that needs to be applied at all times.

Latest applications have stringent link loss requirements and in order to ensure that the required performances levels are achieved during commissioning and operation, the cleanliness of all fibre interfaces needs to be maintained.

The Aginode **OF connector Inspection, Cleaning & Testing general guidelines** can be downloaded [here](#)

Disclaimer

This document is a guideline only. International and local procedures and safety standards must be observed and followed at all times.

Aginode Cabling Systems will not be held liable for any damage or injury to personnel, equipment or business directly or indirectly as a result of using this document in part or in whole.

The practices contained herein are designed as a guide for use by persons having the required technical skill at their own discretion and risk. The recommended practices are based on average conditions.



Aginode does not guarantee any favourable results or assume any liability in connection with this document.

Aginode does not assume any responsibility for the accuracy or completeness of this document. The user should review the information to ensure conformity to the current applicable codes and regulations and to the project requirements.

Aginode reserves the right to change the technical specifications at any time without notice.

Edition 08.01.2014
Copyright © Aginode 2014
All data subject to change
without prior notice.