

Document : ABS1626/B
Date : 30/03/2026

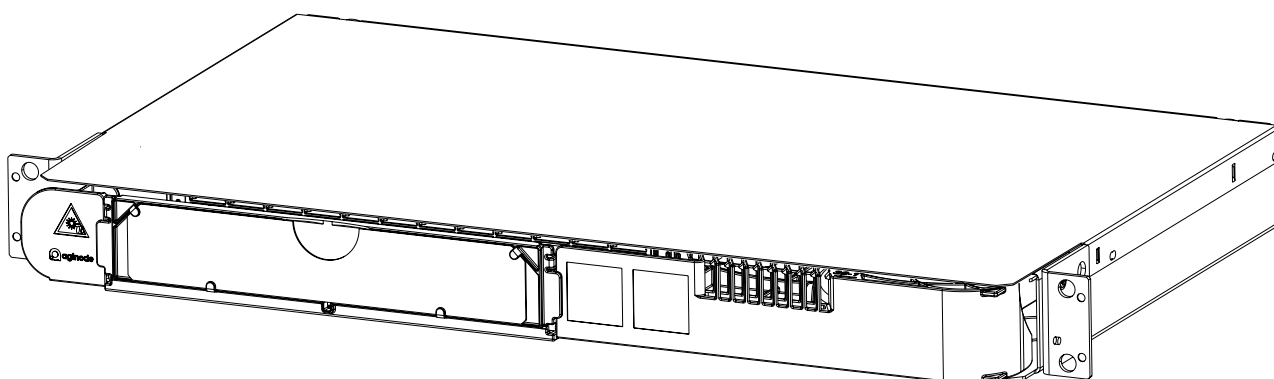

#smartconnection

NOTICE / INSTRUCTIONS



POB 36 2+

Plateau d'épissurage, brassage et lovage (SC simplex)
Splicing, patching and coiling module (SC simplex)

www.aginode.net



Table des matières

Table Of Contents

1. DESCRIPTION OVERVIEW	4
1.1. PRÉSENTATION DU PRODUIT PRODUCT PRESENTATION	4
1.2. DIMENSIONS (MM) DIMENSIONS (MM)	5
1.3. ACCESSOIRES FOURNIS PROVIDED ACCESSORIES	6
2. OUVERTURE DU MODULE OPENING THE MODULE	6
3. FIXATION DU MODULE DANS LA BAIE MODULE INSTALLATION IN THE CABINET	7
4. INSTALLATION D'UN CÂBLE RÉSEAU NETWORK CABLE INSTALLATION	9
4.1. PRÉPARATION DU CÂBLE 36 FO ET DES TUBES DE RETUBAGE 36 FO CABLE AND PROTECTIVE TUBES PREPARATION	9
4.2. INSTALLATION DU CÂBLE ET ACHÈMINEMENT DES FIBRES JUSQU'ÀUX CASSETTES INSTALLATION OF THE CABLE AND ROUTING FIBRES TO THE CASSETTES	10
4.3. ÉPISSURAGE SPLICING	12
5. CAS D'UN MODULE 2U 72FO CASE OF A 2U 72FO MODULE	13
5.1. FIXATION ET PRÉPARATION DU MODULE DANS LA BAIE FIXING AND PREPARING THE MODULE IN THE CABINET	13
5.2. CÂBLAGE DU MODULE 2U WIRING THE 2U MODULE	14
6. RACCORDEMENT DES CORDONS EN FACE AVANT PATCHCORDS CONNECTION AT THE FRONT	16
7. FERMETURE DU MODULE CLOSING THE MODULE	17
8. MAINTENANCE MAINTENANCE	18
8.1. REMPLACEMENT D'UN PIGTAIL PIGTAIL REPLACEMENT	18
8.2. REMPLACEMENT D'UN RACCORD ADAPTER REPLACEMENT	19
8.3. REMPLACEMENT D'UN CORDON PATCHCORD REPLACEMENT	20

**9. INSTRUCTIONS DE FIN DE VIE
END LIFE INSTRUCTIONS..... 21**

ANNEXE / APPENDICE

**A. DEP 1 CÂBLE & 6 TUBES
DEP 1 CABLE & 6 TUBES..... 22**

PRÉSENTATION
OVERVIEW..... 22

PRÉPARATION DU DEP
DEVICE PREPARATION 23

PRÉPARATION DU CÂBLE
CABLE PREPARATION..... 23

MONTAGE DU CÂBLE SUR LE DEP
CABLE MOUNTING ON THE DEVICE..... 23

INSTALLATION DES TUBES Ø 5MM
Ø 5MM TUBES INSTALLATION..... 24

FERMETURE DU DEP
DEVICE CLOSURE 25

FIXATION DU DEP
DEVICE FIXATION..... 25



Les schémas qui suivent représentent un module axe à droite : l'installation d'un module axe à gauche se fait de manière similaire.

Le version représentée ici possède 36 points de connexion SC simplex.

The following drawings illustrate the use of a right-axis module : mounting of a left-axis module is performed in the same way.

The version illustrated hereafter possesses 36 SC simplex connection points.

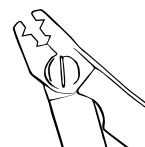
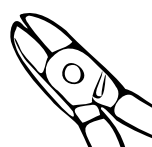
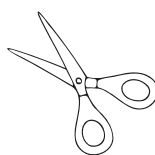
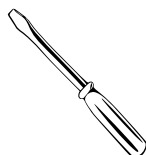

1. DESCRIPTION OVERVIEW

1.1. Présentation du produit Product presentation

- | | | | |
|-----|--|-----|---|
| 1- | Châssis fixe 1U | 1- | Fixed chassis 1U |
| 2- | Capot de protection amovible | 2- | Removable protective cover |
| 3- | Entrées de câbles | 3- | Entries cables |
| 4- | Zone de fixation de l'épanouisseur | 4- | Fixation area for the clamping device |
| 5- | Trou de passage pour bloodite | 5- | Hole for bloodite passage |
| 6- | Equerre 19"/ETSI | 6- | 19"/ETSI Bracket |
| 7- | Peigne pour la sortie des cordons | 7- | Comb for patchcords exit |
| 8- | Zone QR CODE | 8- | Area for QR CODE |
| 9- | Zone de lovage des surlongueurs des cordons | 9- | Coiling area for patchcords overlengths |
| 10- | Bandeau de brassage 36 raccords SC simplex | 10- | Patch panel for 36 SC simplex adapters |
| 11- | Volet porte étiquette | 11- | Label holder flap |
| 12- | Organiseur équipé de 3 cassettes d'épissure 12FO | 12- | Organizer equipped with 3 splice cassettes 12OF |
| 13- | Ensemble optique pivotant | 13- | Swivelling optical assembly |
| 14- | Zone de lovage des surlongueurs des micromodules | 14- | Coiling area for microbundles overlengths |

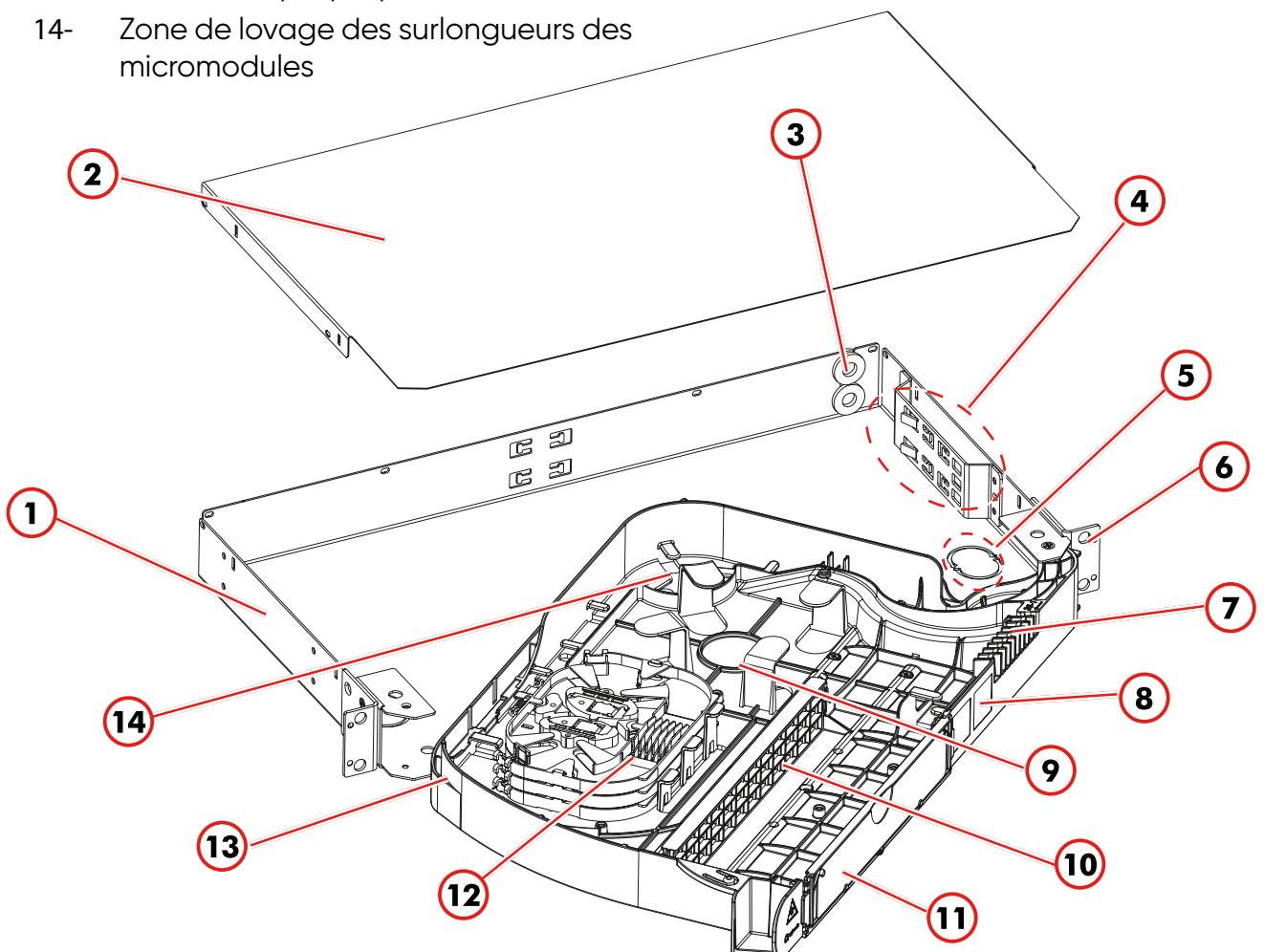

1.2. Dimensions (mm)
Dimensions (mm)

Avec plaque de fixation 19'
With 19' fixation plate

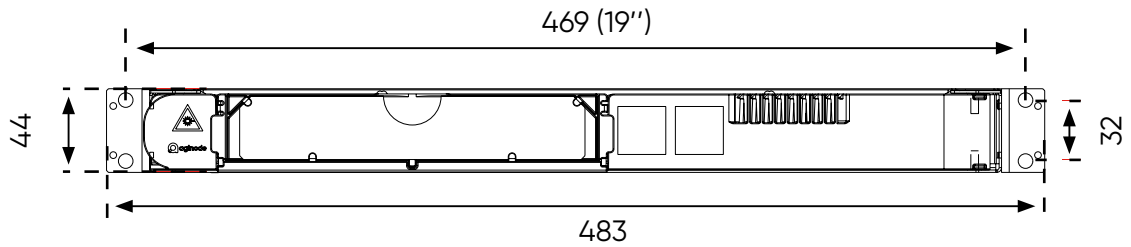

Avec plaque de fixation ETSI
With ETSI fixation plate

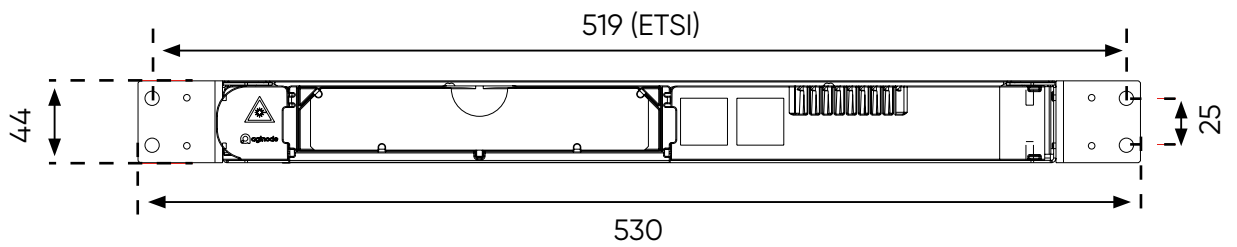

1.3. Accessoires fournis
Provided accessories

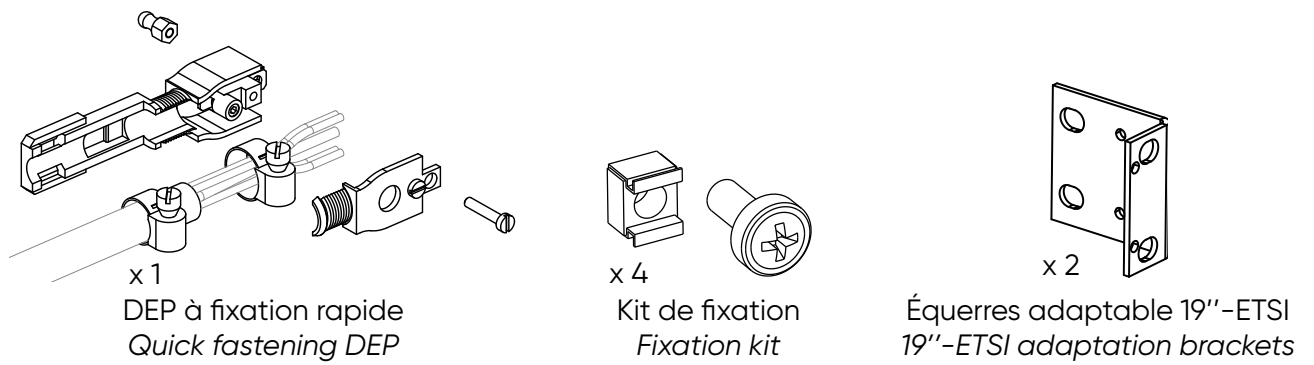

2. **OUVERTURE DU MODULE**
OPENING THE MODULE

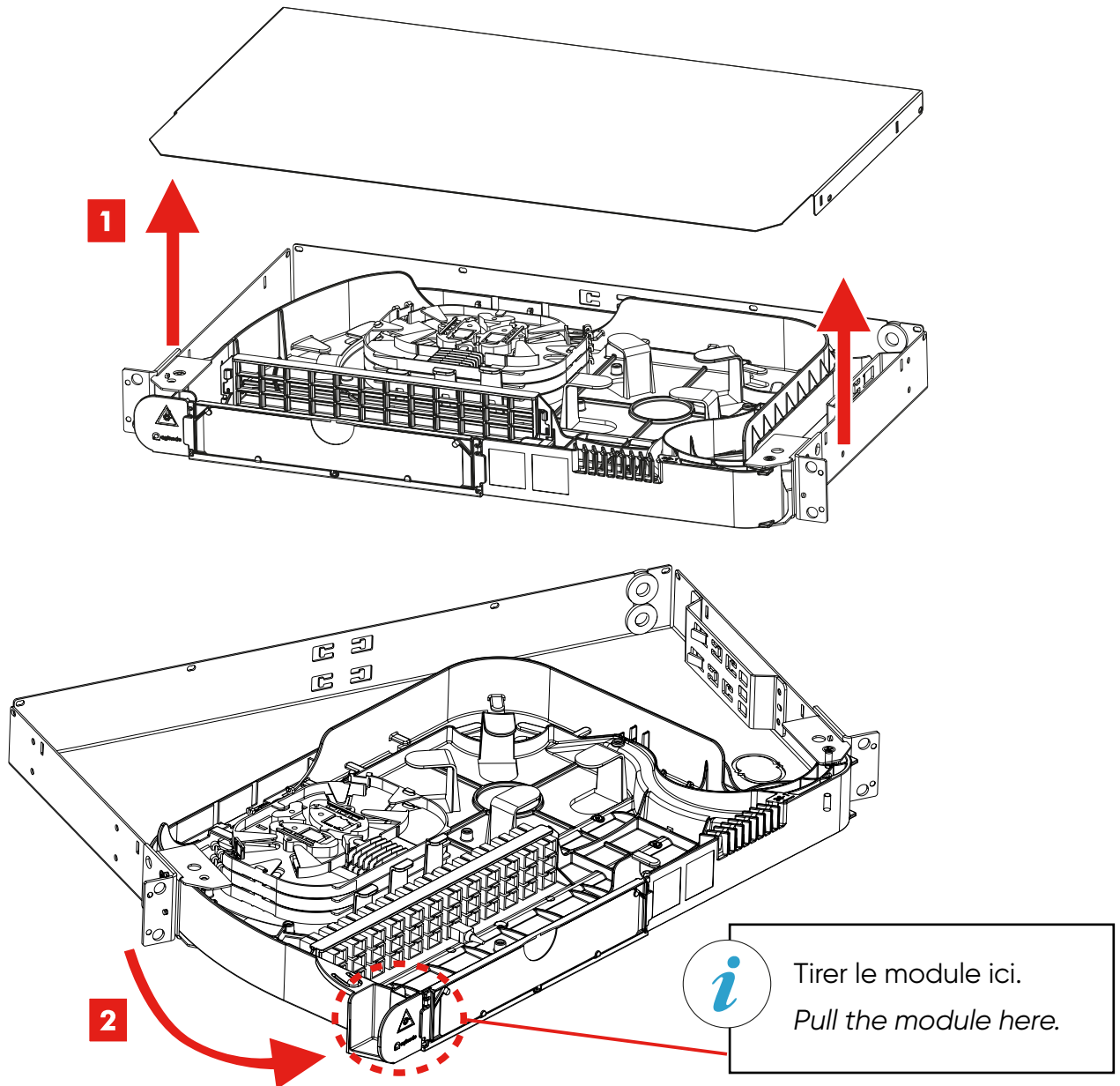

3. FIXATION DU MODULE DANS LA BAIE
MODULE INSTALLATION IN THE CABINET

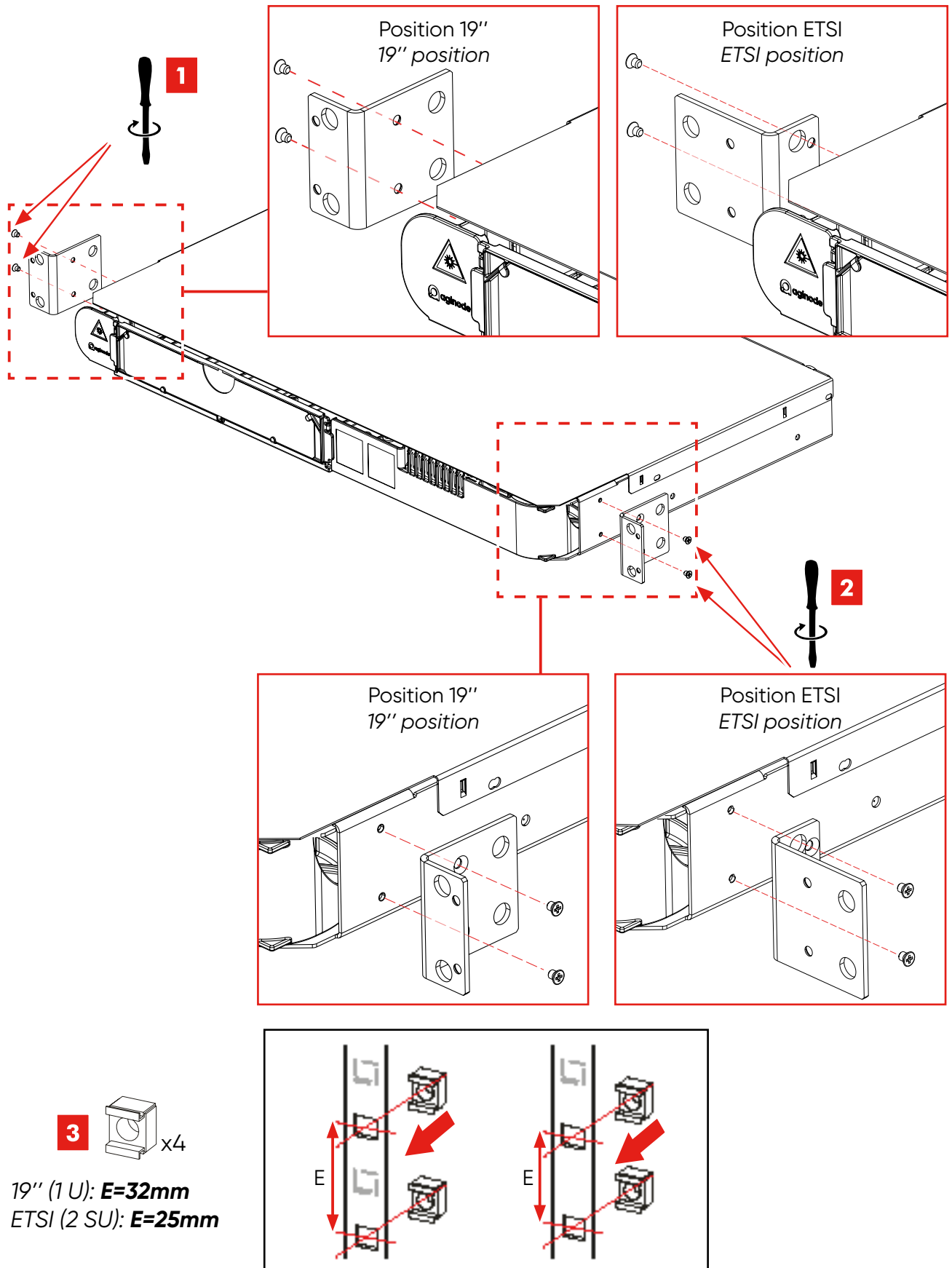



Autre manière de mettre en place les équerres 19" et ETSI, afin d'augmenter la place entre l'arrière du module et le fond de l'armoaire.

Another way of installing the 19" and ETSI brackets, to increase the space between the rear of the module and the back of the cabinet.

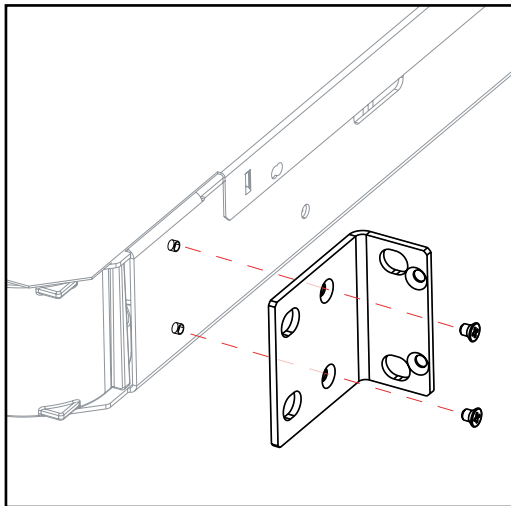

Version 19"

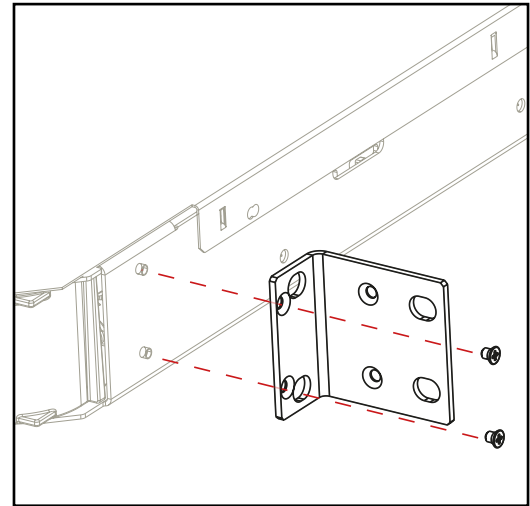

Version ETSI

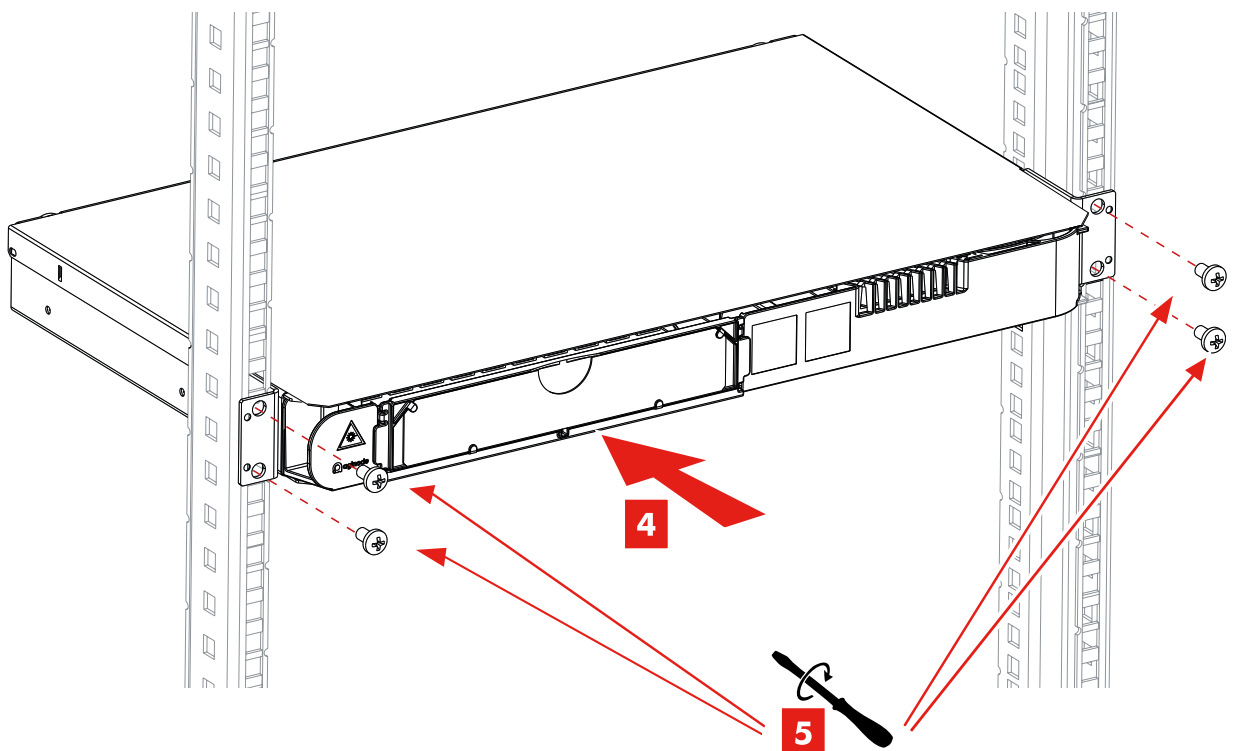

4. INSTALLATION D'UN CÂBLE RÉSEAU NETWORK CABLE INSTALLATION

4.1. Préparation du câble 36 FO et des tubes de retubage 36 FO Cable and protective tubes preparation



Voir les instructions fournies avec le dispositif d'épanouissement. (voir en annexe page 22)

Refer to the instructions provided with the fanout device. (see the appendix page 22)

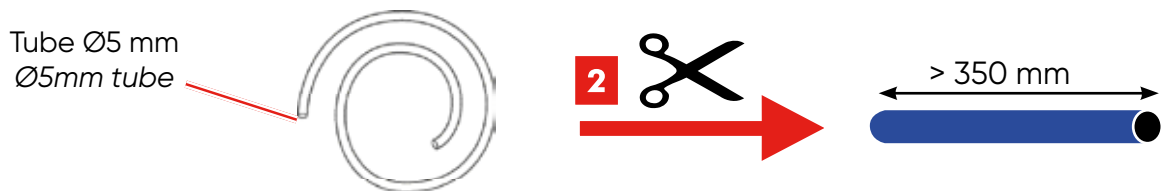
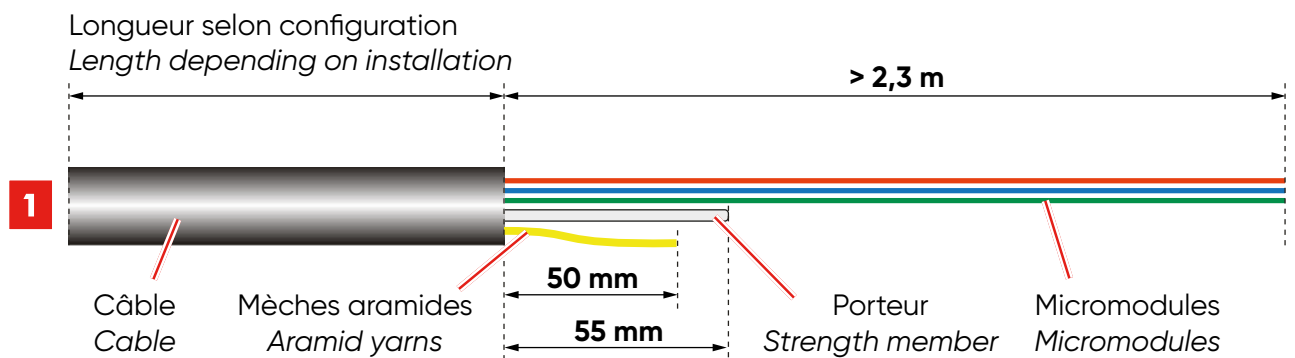

4.2. Installation du câble et acheminement des fibres jusqu'aux cassettes
 Installation of the cable and routing fibres to the cassettes

Sortir le joint, le percer, insérer le câble et le remettre en place
 Remove the gasket, pierce it, insert the cable and replace it

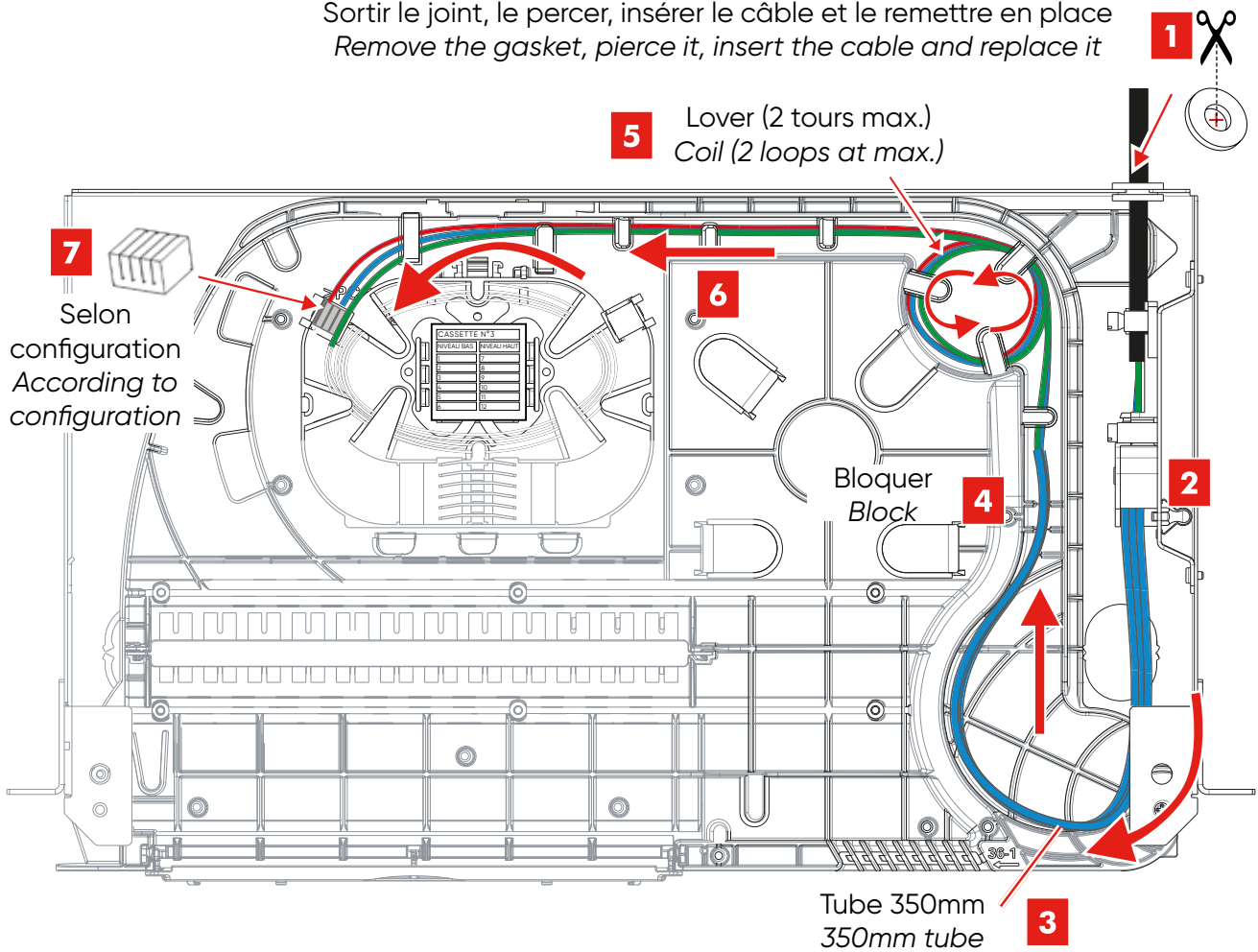

Possibilité de fixer le câble à l'arrière du module sur les T d'arrimage à l'aide de deux colliers plastiques

Possibility to secure the cable at the rear of the module to the T-clamps using two plastic ties

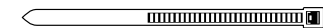

x2 (non fourni)
(not provided)

Vue face interne du module
Internal view of the module

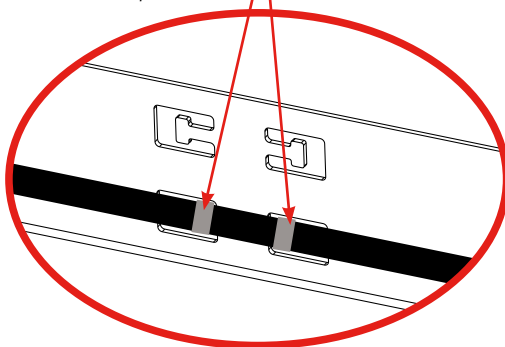

Vue arrière externe du module
External rear view of the module

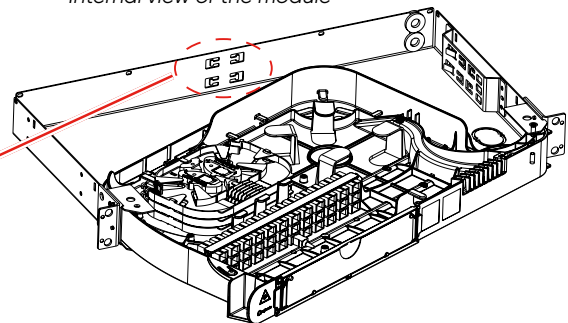



Ordre de raccordement des cassettes:
de bas en haut.

12fo max./cassette

*Cassettes connection order: from
bottom to top.*

12fo max./cassette

- ③ Cassette - fibres 25- 36
- ② Cassette - fibres 13- 24
- ① Cassette - fibres 1 - 12

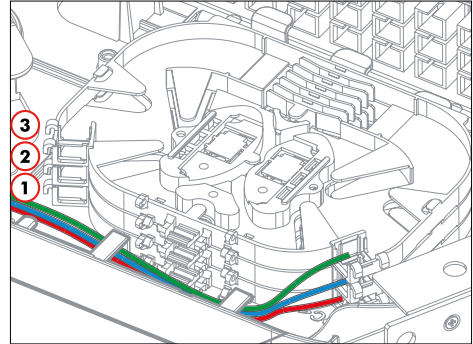



Indications du bandeau de
raccordement pour 36 raccords SC
simplex.

*Patch panel indications for 36 SC
simplex adaptors.*

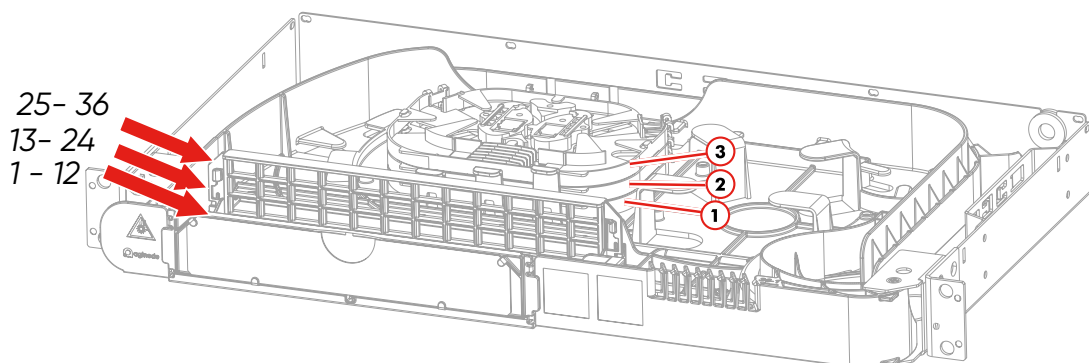
Cassette fibres 25- 36	③	→	UP	25	26	27	28	29	30	31	32	33	34	35	36
Cassette fibres 13- 24	②	→		13	14	15	16	17	18	19	20	21	22	23	24
Cassette fibres 1 - 12	①	→	DOWN	1	2	3	4	5	6	7	8	9	10	11	12

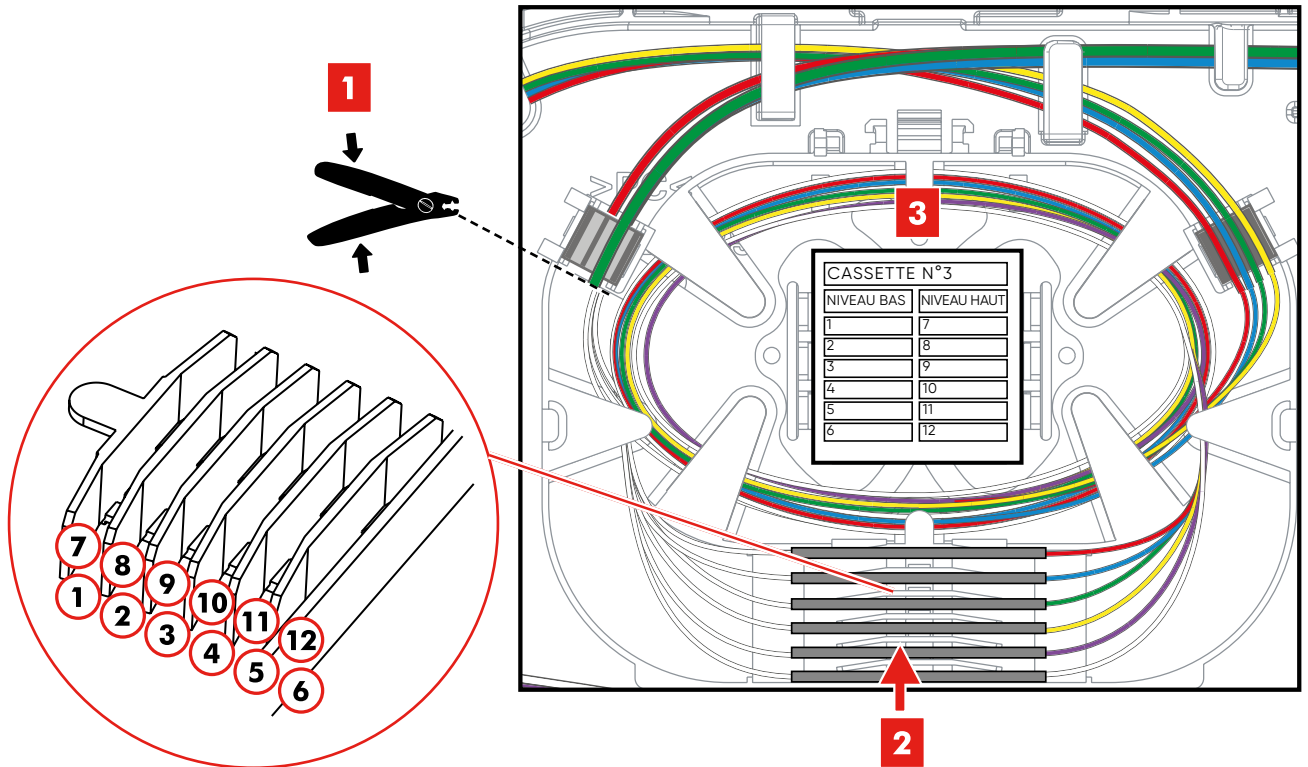

4.3. Épissurage
Splicing



 Longueur du pigtail dans la cassette *Length of pigtail in the cassette 90cm.*
 90cm.

5. CAS D'UN MODULE 2U 72FO CASE OF A 2U 72FO MODULE

5.1. Fixation et préparation du module dans la baie *Fixing and preparing the module in the cabinet*



Pour l'installation d'un module 2U 72 FO, visser un premier module sans capot (A) puis le second module (B) au dessus avec capot.

To install a 2U 72 FO module, screw the first module without cover (A) and then the second module (B) on top with cover.

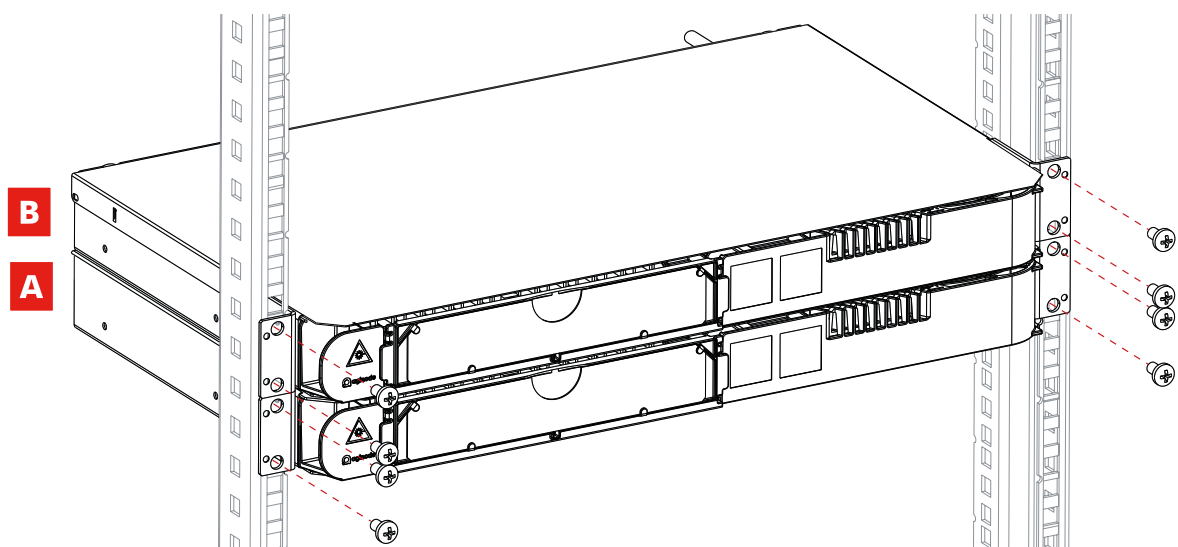

Manipulation à faire avant l'installation du câble 72 FO.

Steps to be taken before installing the 72 FO cable.

Pousser avec les doigts la partie sécable du module (B) supérieur uniquement pour ouvrir le trou de passage pour bloolites.

Use your fingers to push the snap-off part of the top (B) module only to open the hole for the bloolites.

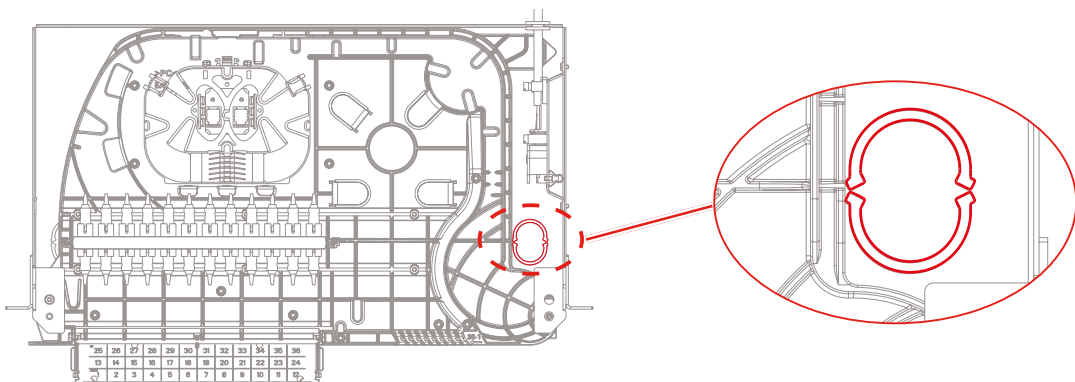

5.2. Câblage du module 2U Wiring the 2U module



La préparation du câble 72 FO sera identique à celle du 36 FO.

The preparation of the 72 OF cable will be the same as that of the 36 OF cable.

Les 3 bloopites situés dans la partie supérieure du DEP seront installés dans le module supérieur (B), tandis que les 3 restants iront dans le module inférieur (A) en passant par le trou de passage mentionné page 12.

The 3 bloopites located in the upper part of the DEP will be installed in the upper module (B), while the remaining 3 will go into the lower module (A) via the through-hole mentioned on page 12.

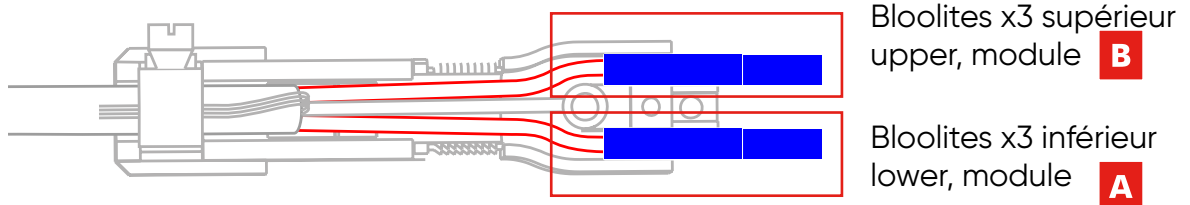

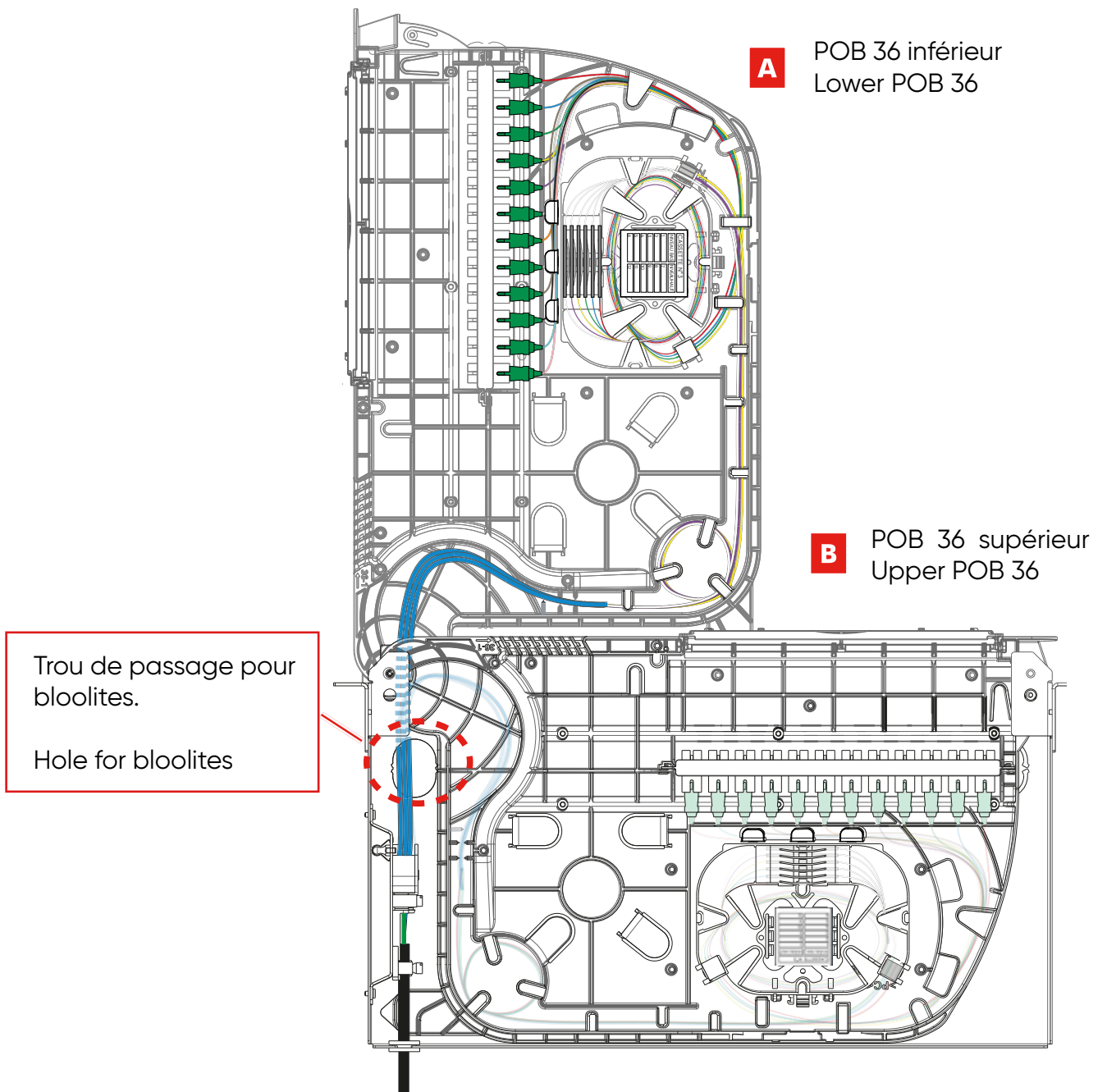

i L'acheminement vers les cassettes et l'épissage seront similaires au câblage du module 1U POB 36. *Routing to the cassettes and splicing will be similar to the cabling for the 1U POB 36 module.*

6. RACCORDEMENT DES CORDONS EN FACE AVANT PATCHCORDS CONNECTION AT THE FRONT

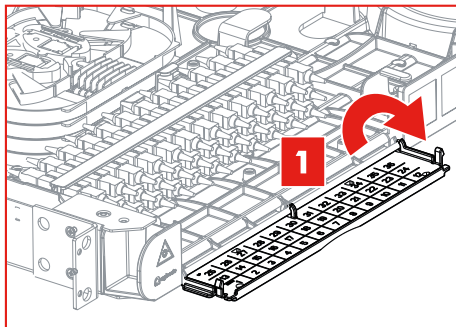

Il est recommandé d'effectuer 2 tours au maximum. *We recommend to perform at maximum 2 loops.*

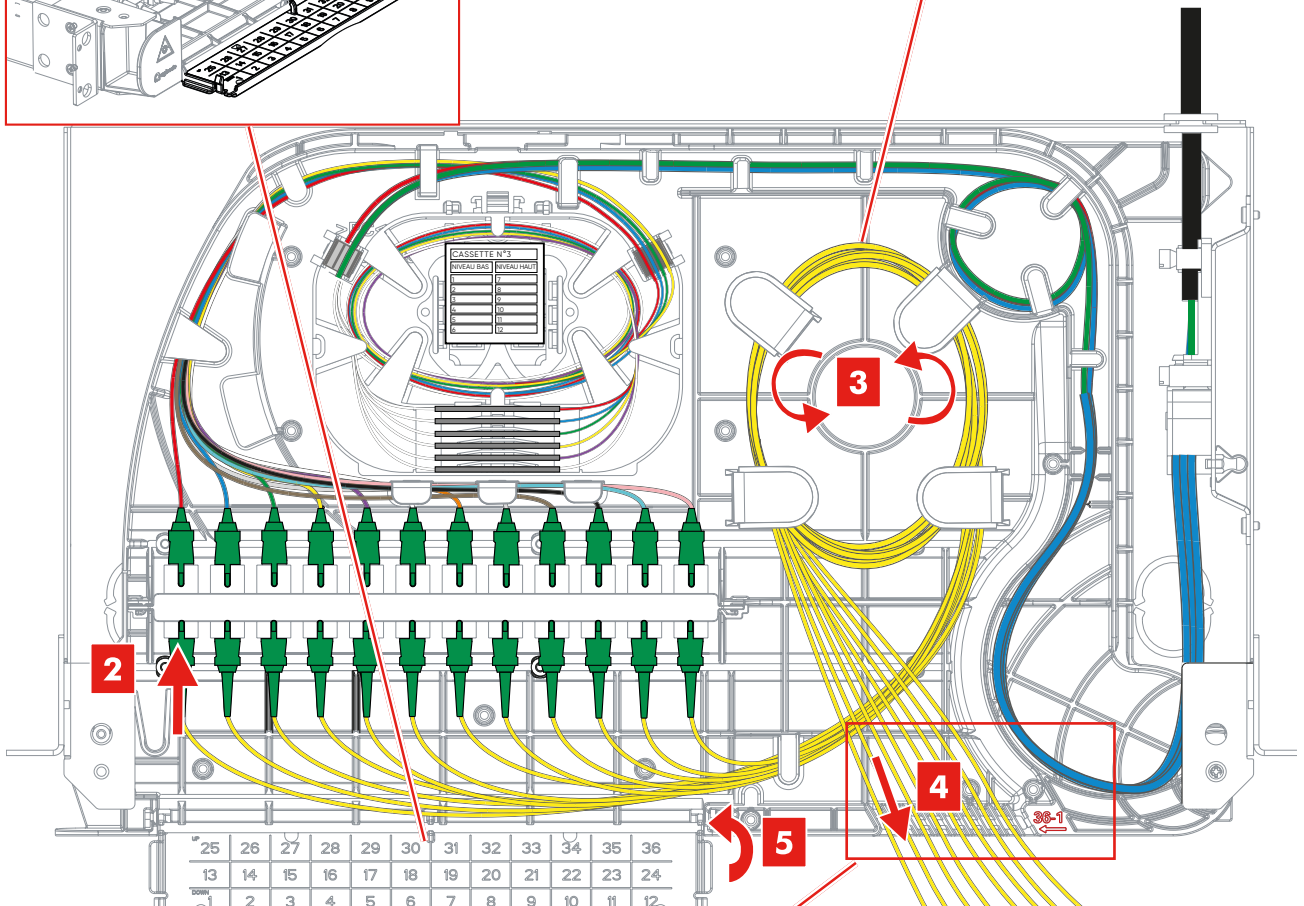

Ordre de remplissage du peigne avant pour les cordons.

Order of filling of the front comb for patchcords.

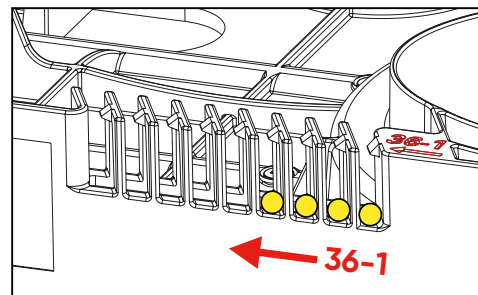

**7. FERMETURE DU MODULE
CLOSING THE MODULE**

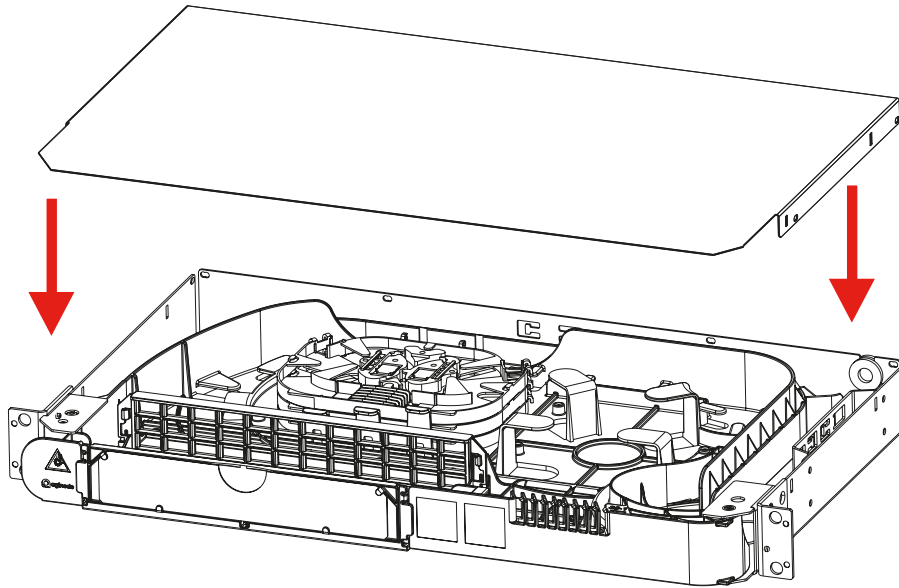

8. MAINTENANCE MAINTENANCE

8.1. Remplacement d'un pigtail *Pigtail replacement*

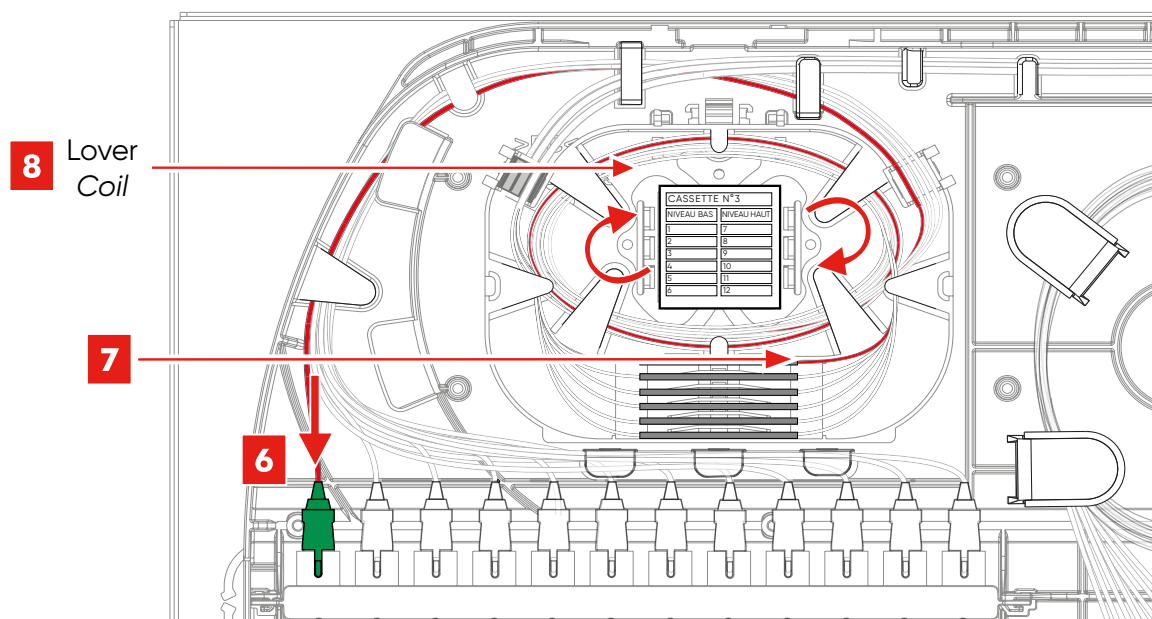
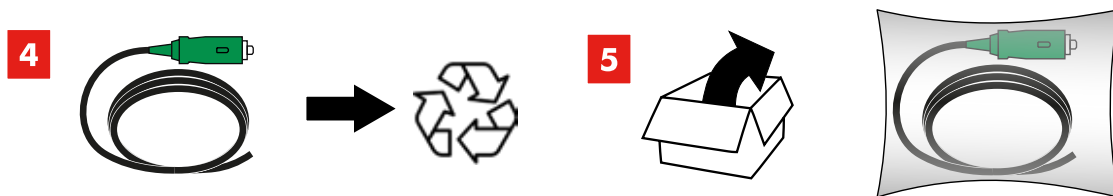
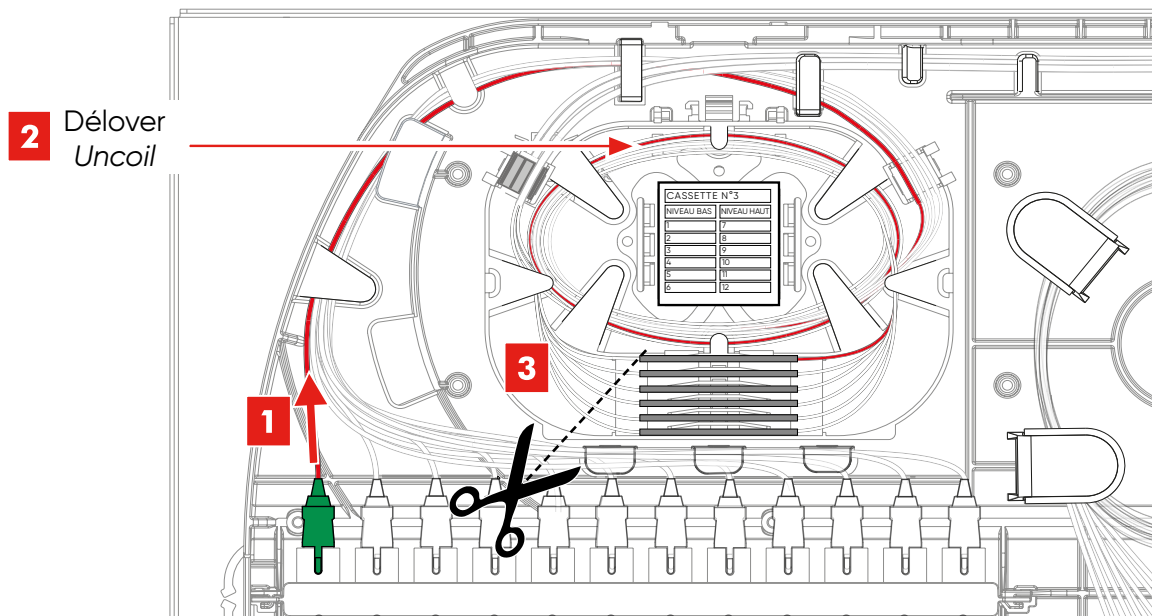

8.2. Remplacement d'un raccord Adapter replacement

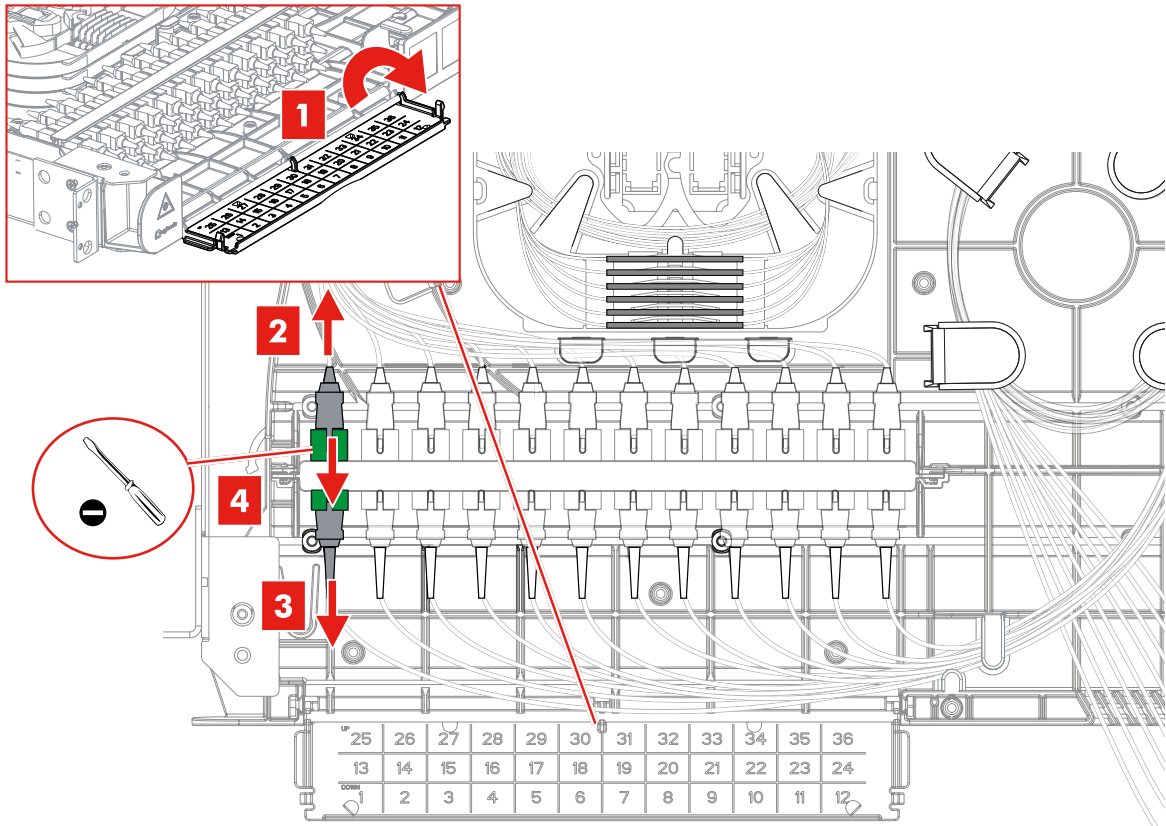

Il est recommandé de faire pression sur le clip avec un tournevis plat pour permettre le retrait du raccord défectueux. (4)

It is advisable to apply pressure to the clip with a flathead screwdriver to enable the defective adapter to be removed. (4)

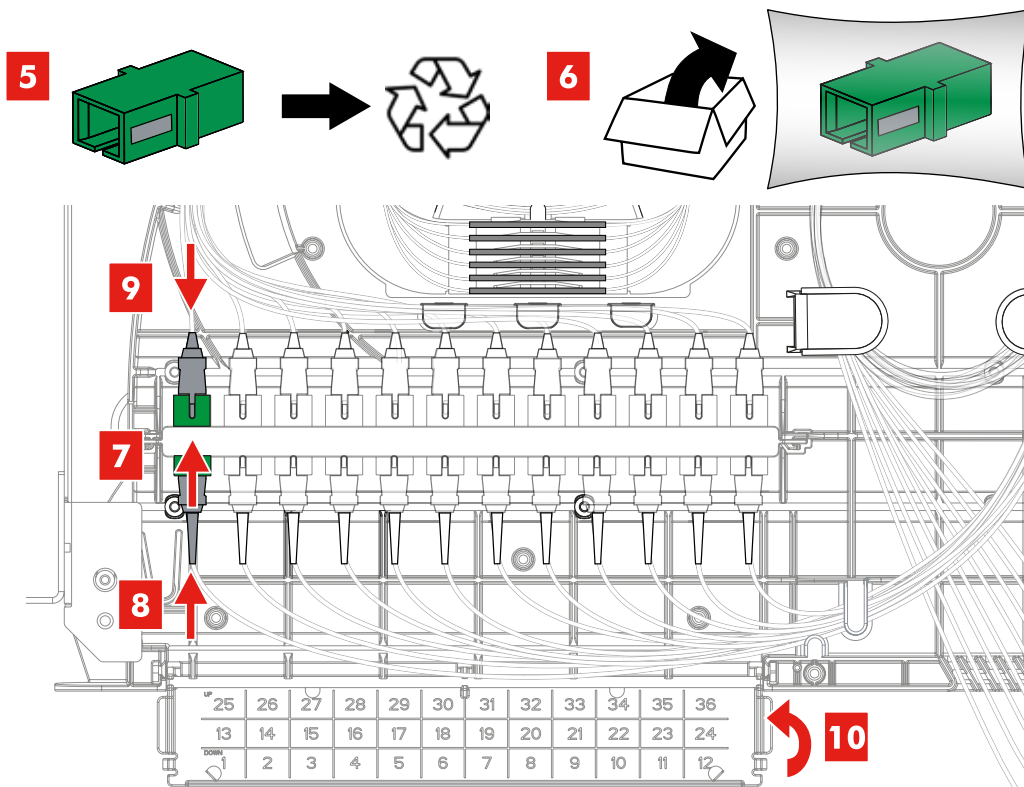

8.3. Remplacement d'un cordon
Patchcord replacement

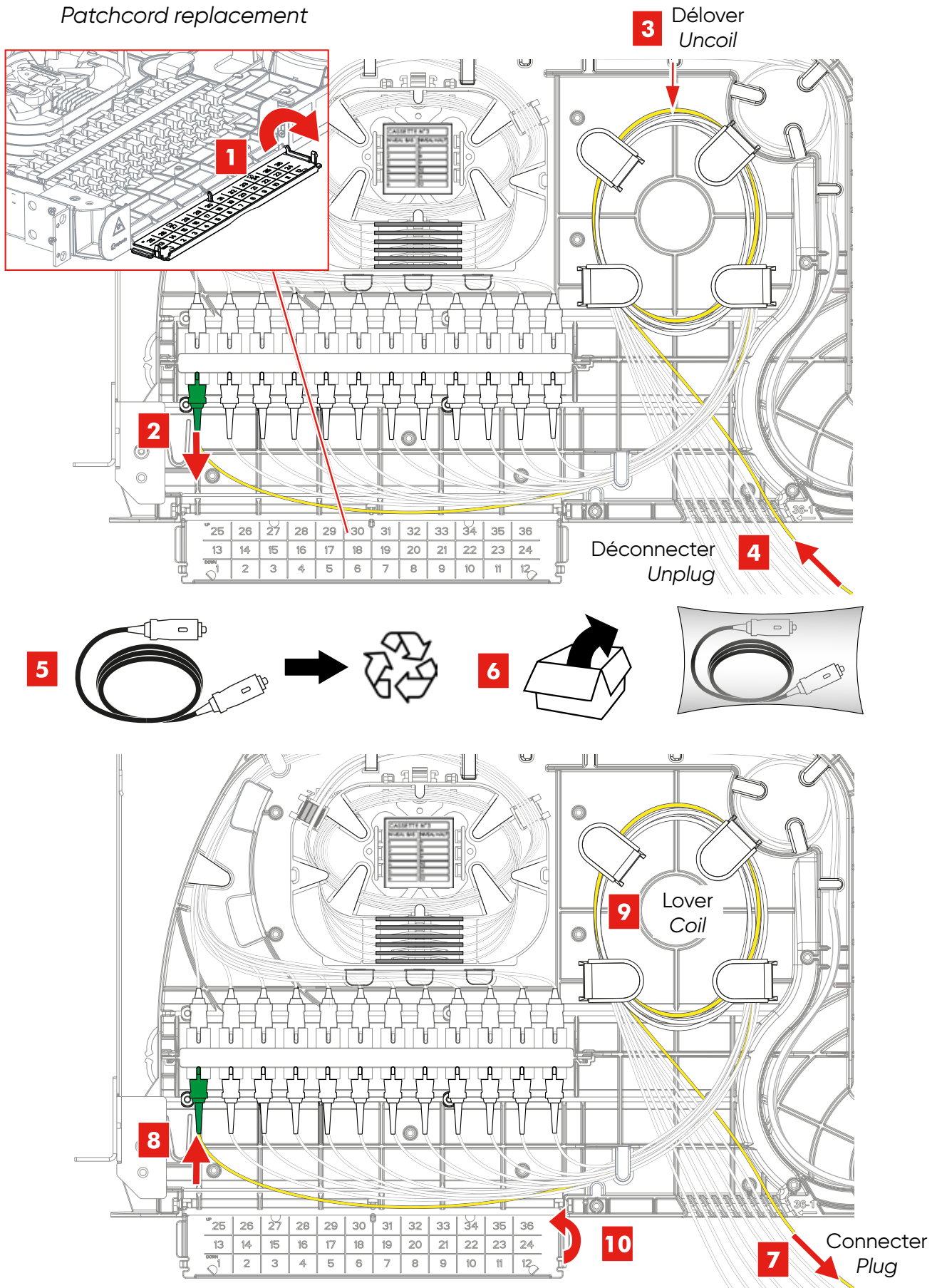

9. INSTRUCTIONS DE FIN DE VIE
END LIFE INSTRUCTIONS



WEEE / DEEE



Pensez à favoriser le réemploi de vos emballages !
Think about reusing your packaging !



Équipement électrique et électronique
Electrical and electronic equipment



Pièce métallique et plastique
Metal and plastic component



Emballage carton, sachet plastique
Cardboard, plastic packaging



Sachet zip réutilisable
Reusable zip bag

ANNEXE / APPENDICE

A. DEP 1 CÂBLE & 6 TUBES DEP 1 CABLE & 6 TUBES

PRÉSENTATION OVERVIEW

- | | | | |
|-----|---|-----|---|
| 1- | 3 colliers métalliques | 1- | 3 metallic collars |
| 2- | Capot | 2- | Cover |
| 3- | Corps | 3- | Base |
| 4- | Tube de protection Ø 5mm | 4- | Protective tube Ø 5mm |
| 5- | Clip de montage | 5- | Mounting clip |
| 6- | Goujon | 6- | Stud |
| 7- | Vis longue 12mm (fixation du goujon) | 7- | Long screw 12mm (stud fixing) |
| 8- | Languette métallique (anti-cisaillement) | 8- | Metal tongue (anti-shear) |
| 9- | Vis hexagonale creuse (fixation du porteur) | 9- | Hollow hex screw (strength member fixing) |
| 10- | Vis courte 6,5mm (fixation du capot) | 10- | Short screw 6.5mm (cover fixing) |
| 11- | Clef Allen | 11- | Hex key |

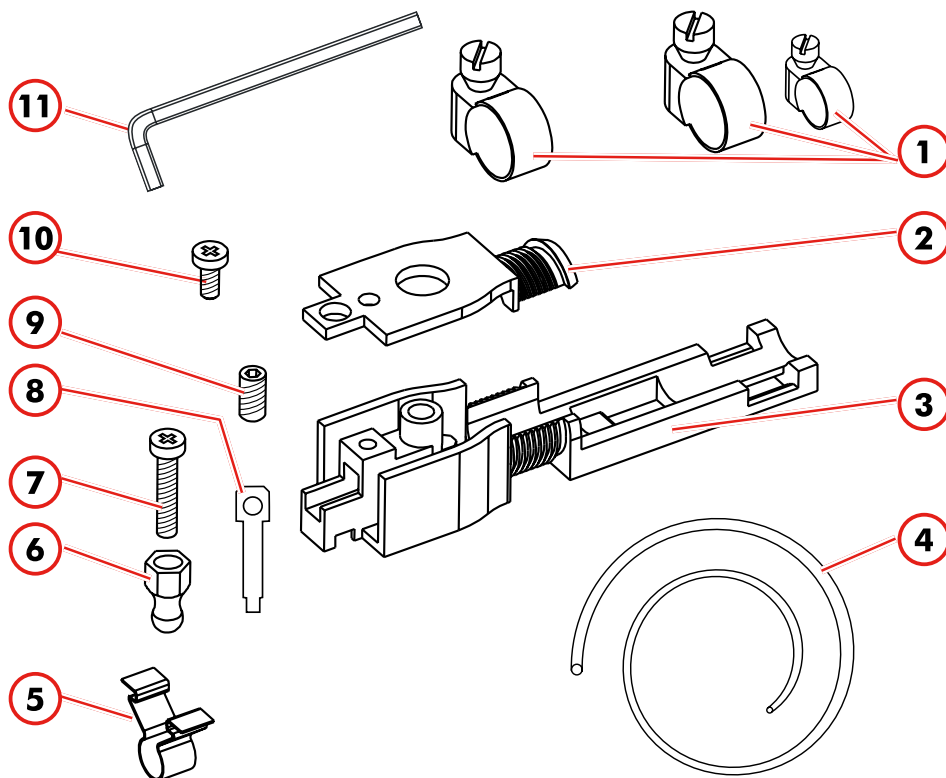

PRÉPARATION DU DEP
DEVICE PREPARATION

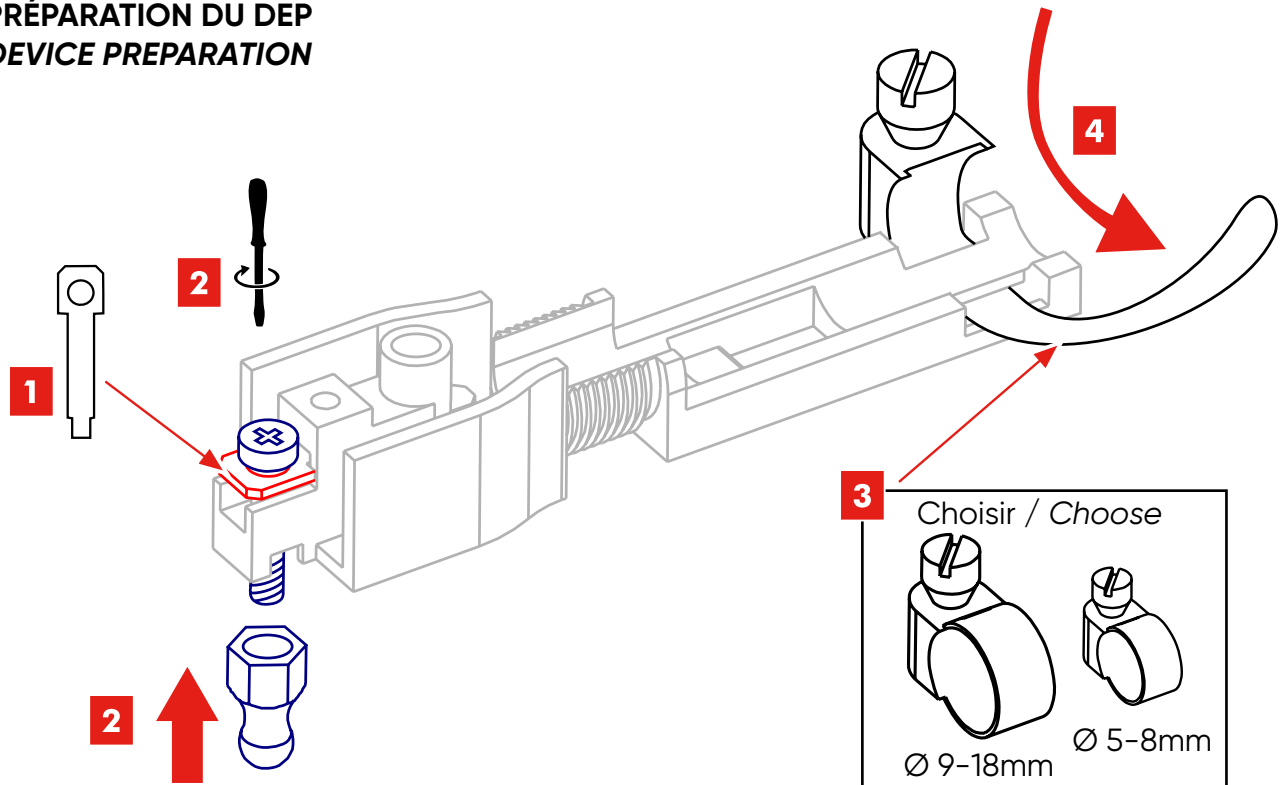

PRÉPARATION DU CÂBLE
CABLE PREPARATION

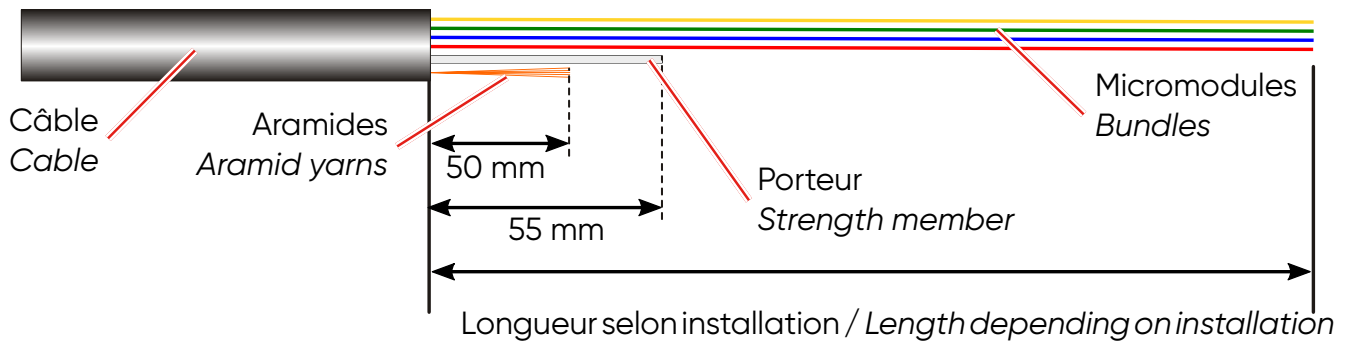

MONTAGE DU CÂBLE SUR LE DEP
CABLE MOUNTING ON THE DEVICE

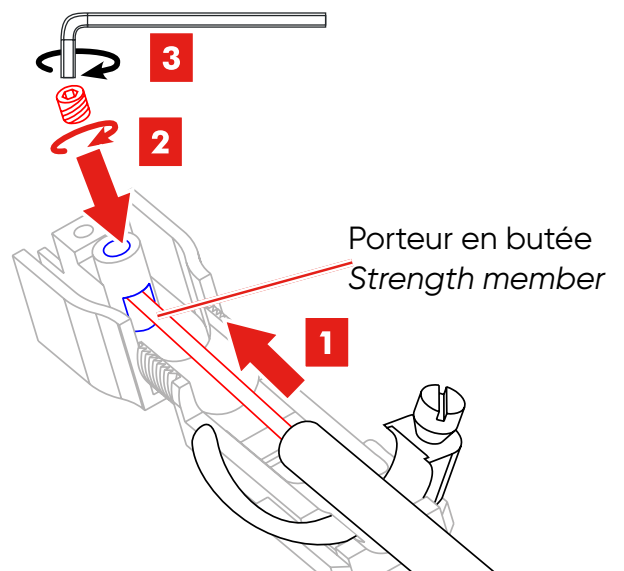

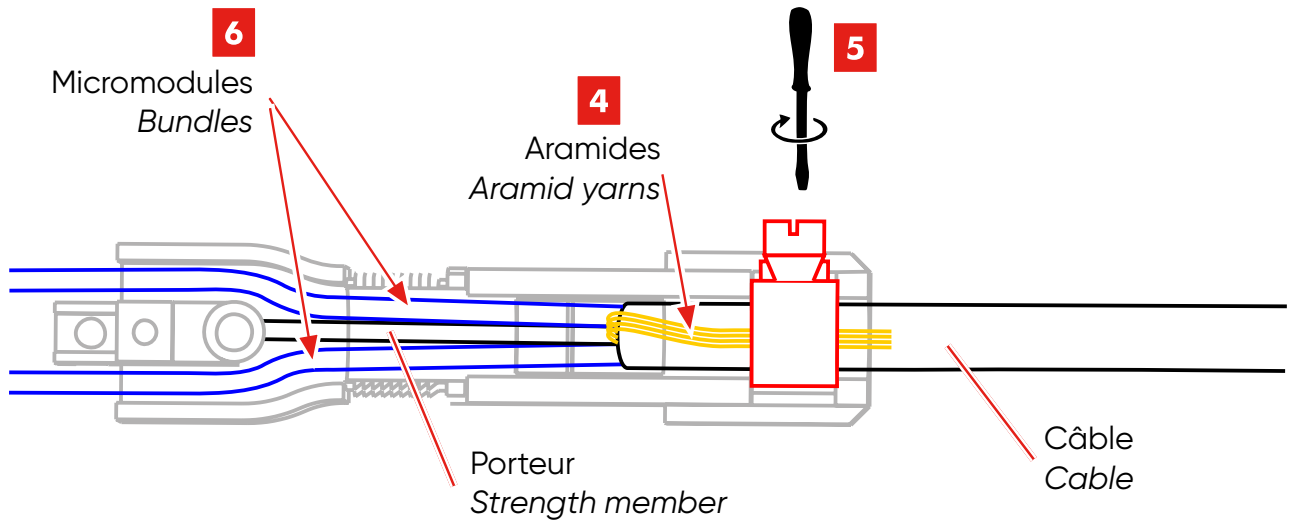

INSTALLATION DES TUBES Ø 5MM
Ø 5MM TUBES INSTALLATION

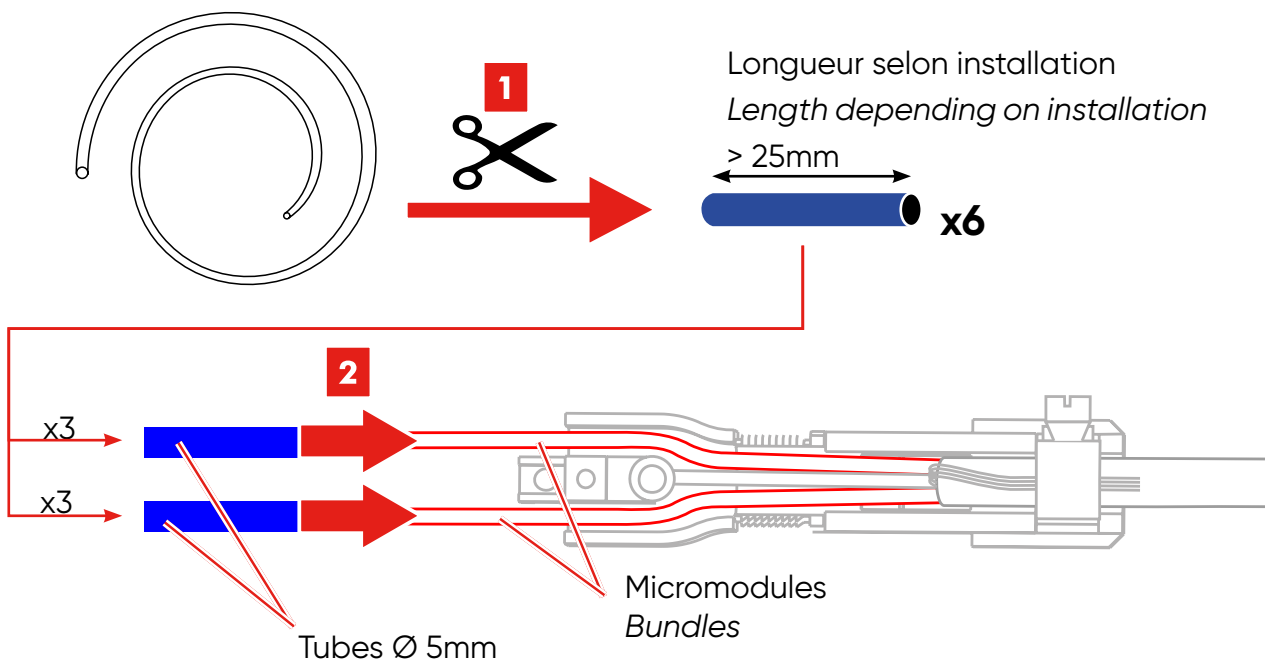

Exemple d'installation avec 2 tubes contenant des fibres et 4 cales :

Example of installation with 2 tubes containing fibers and 4 wedges:

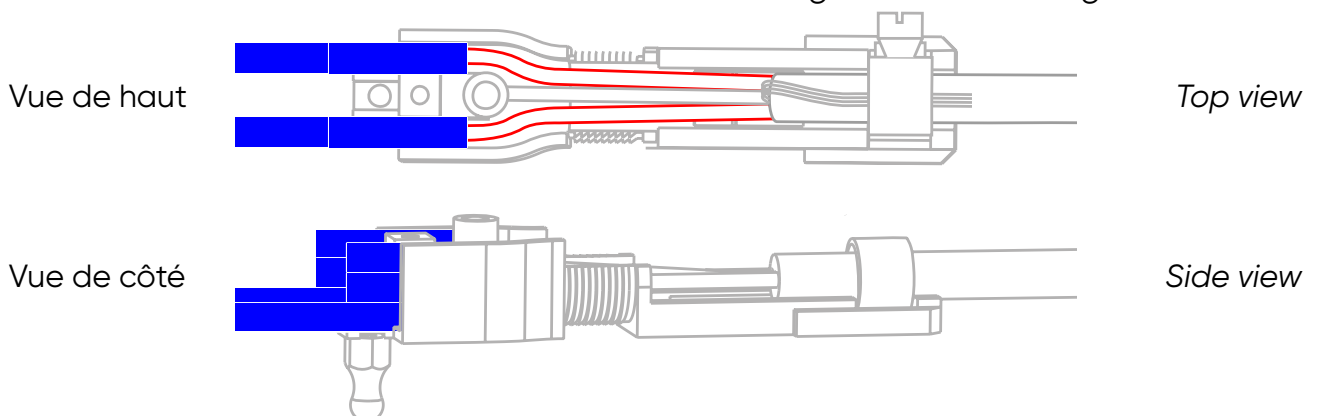

FERMETURE DU DEP
DEVICE CLOSURE

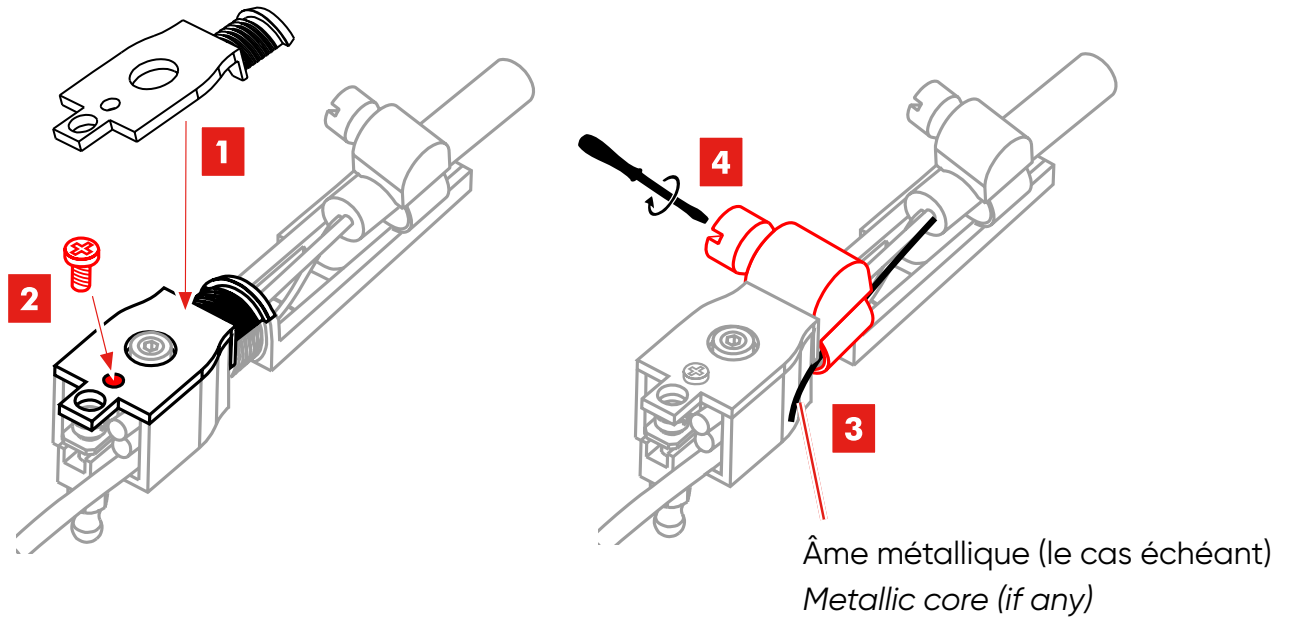

FIXATION DU DEP
DEVICE FIXATION

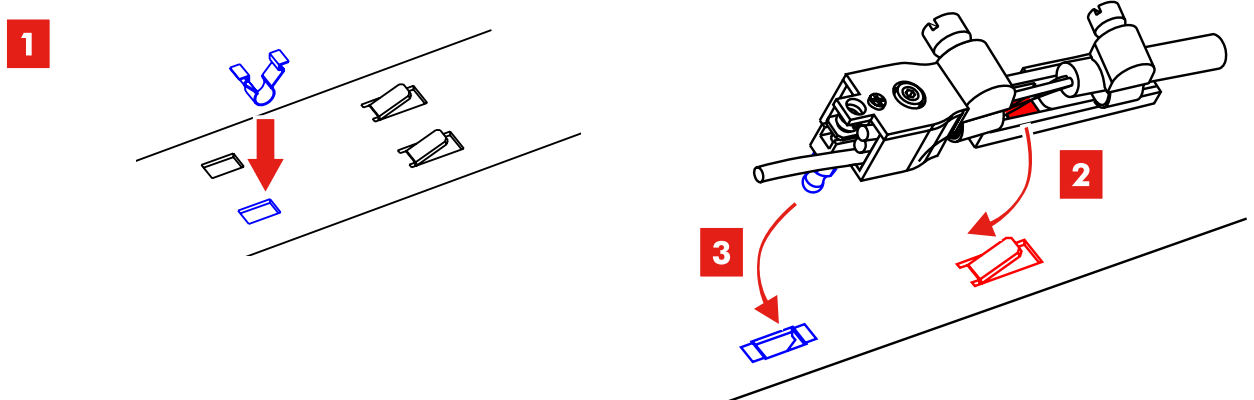

 **Se connecter via LinkedIn**
Connect via LinkedIn











En savoir plus sur Youtube
Learn more on YouTube

Visiter www.aginode.net
Visit www.aginode.net

Contactez-nous via
Contact us via
info@aginode.net

AGINODE
1, rue Pierre Viénot
08330 Vrigne-aux-Bois
FRANCE
Tel. +33 (0) 3 24 52 61 61