

Document : ABS0509/G
Date : 29/07/2024



#smartconnection

NOTICE / INSTRUCTIONS



CROS PLUS 1

Cassettes

www.aginode.net



Table des matières

Table Of Contents

1. PRÉSENTATION	
OVERVIEW	4
1.1. 3 VERSIONS DISPONIBLES	
AVAILABLE IN 3 VERSIONS	4
1.2. DESCRIPTION DU PRODUIT	
PRODUCT DESCRIPTION	5
2. FIXATION MURALE	
WALL FIXING	6
2.1. OUVERTURE	
OPENING	6
2.2. FIXATION	
FIXING	7
3. PRÉPARATION DU BOÎTIER	
BOX PREPARATION	7
3.1. MONTAGE DES RACCORDS	
ADAPTERS MOUNTING	7
3.2. MONTAGE DES KITS DE GESTION DES JARRETIÈRES	
MOUNTING PATCHCORDS MANAGEMENT KITS	8
3.3. PRÉPARATION DES CASSETTES	
CASSETTES PREPARATION	9
3.4. INSTALLATION DES PIGTAILS (LE CAS ÉCHÉANT)	
PIGTAILS INSTALLATION (WHERE APPROPRIATE)	9
4. MISE EN PLACE DES CÂBLES D'ARRIVÉE	
INCOMING CABLES INSTALLATION	10
4.1. PRÉPARATION D'UN CÂBLE EN TERMINAISON	
TERMINATING CABLE PREPARATION	10
4.2. PRÉPARATION D'UN CÂBLE EN PIQUAGE	
MIDSPAN CABLE PREPARATION	10
4.3. ARRIMAGE	
CABLE CLAMPING	10
4.4. ACHEMINEMENT DES FIBRES	
FIBRES ROUTING	11
4.5. EPISSURAGE	
SPLICING	12

Table des matières

5.	MISE EN PLACE DES JARRETIÈRES PATCHCORDS INSTALLATION.....	12
6.	MISE À LA TERRE EARTHING.....	13
7.	INSTRUCTIONS DE FIN DE VIE END LIFE INSTRUCTIONS.....	14

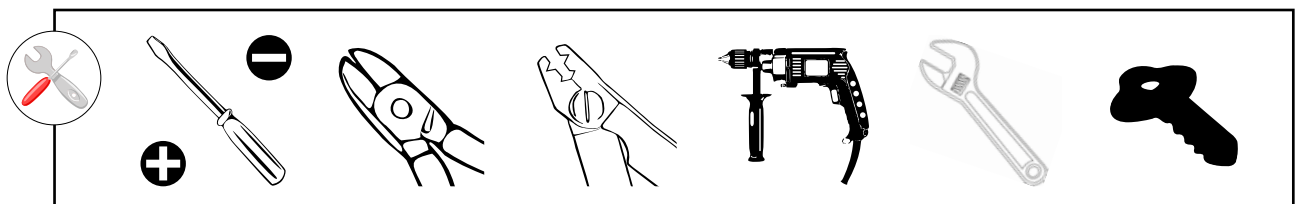

1. PRÉSENTATION OVERVIEW

1.1. 3 versions disponibles
Available in 3 versions

1.1.1. Type B1 (IP 50)

- A. Entrée de câbles par le bas, avec une brosse.
Incoming cables at the bottom, with a brush.
- B. Sortie de jarretières hautes ou basses, avec une brosse.
Patchcords output top or bottom, with a brush.

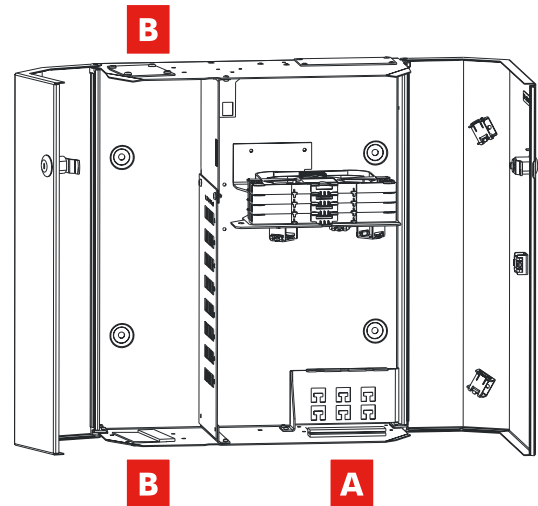

1.1.2. Type B2 (IP 54)

- A. Entrée de câbles par le bas, avec 3 passe-fils.
Incoming cables at the bottom, with grommets.
- B. Sortie de jarretières par le bas, avec un passe-fils.
Patchcords output at the bottom, with a sealing.

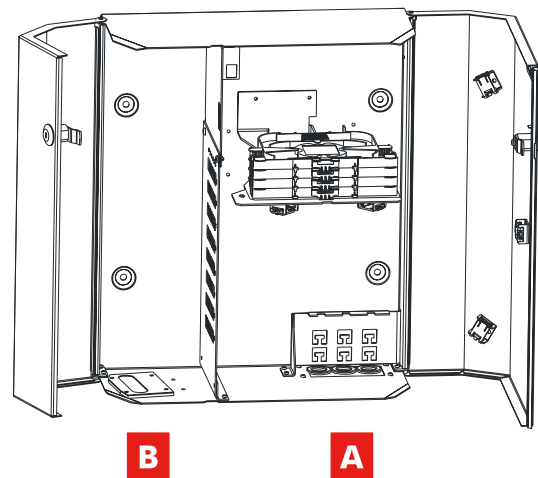

1.1.3. Type T1 (IP 50)

- A. Entrée de câbles par le haut, avec une brosse.
Incoming cables at the top, with a brush.
- B. Sortie de jarretières hautes ou basses, avec une brosse.
Patchcords output top or bottom, with a brush.

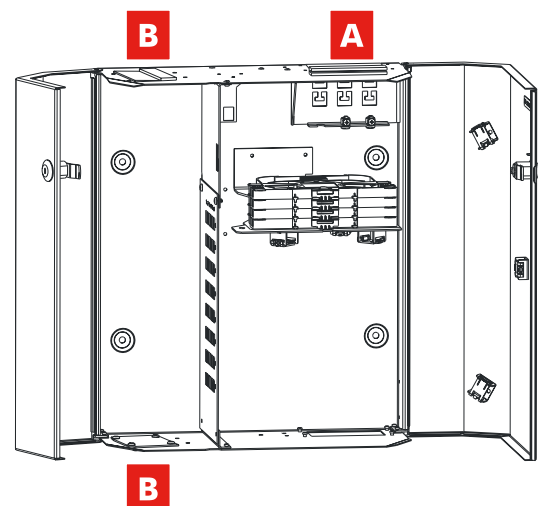

1.2. Description du produit *Product description*

- | | |
|--|---|
| 1. Boîtier de base CROS PLUS 1 | 1. Base box CROS PLUS 1 |
| 2. Bandeau de brassage de 24,36 ou 48 raccords de type SC ou FC à vis | 2. Patch panel for 24 ,36 or 48 adapters type SC or FC with screw |
| 3. Organiseur de 1 à 4 cassettes standard | 3. Organizer with 1 to 4 standard cassettes |
| 4. Porte de sécurisation « OPERATEUR » fermant à clé, permettant le lovage des tubes | 4. «OPERATOR» security door with key, and a area for coiling the tubes, |
| 5. Dispositif d'arrimage des câbles | 5. Cable clamping device |
| 6. Dispositif de protection des entrées de câbles | 6. Input cables protection device |
| 7. Dispositif de protection des jarretières sortantes | 7. Output patchcords protection device |
| 8. Porte de sécurisation « ABONNES » fermant à clé | 8. «SUBSCRIBERS» security door with key |

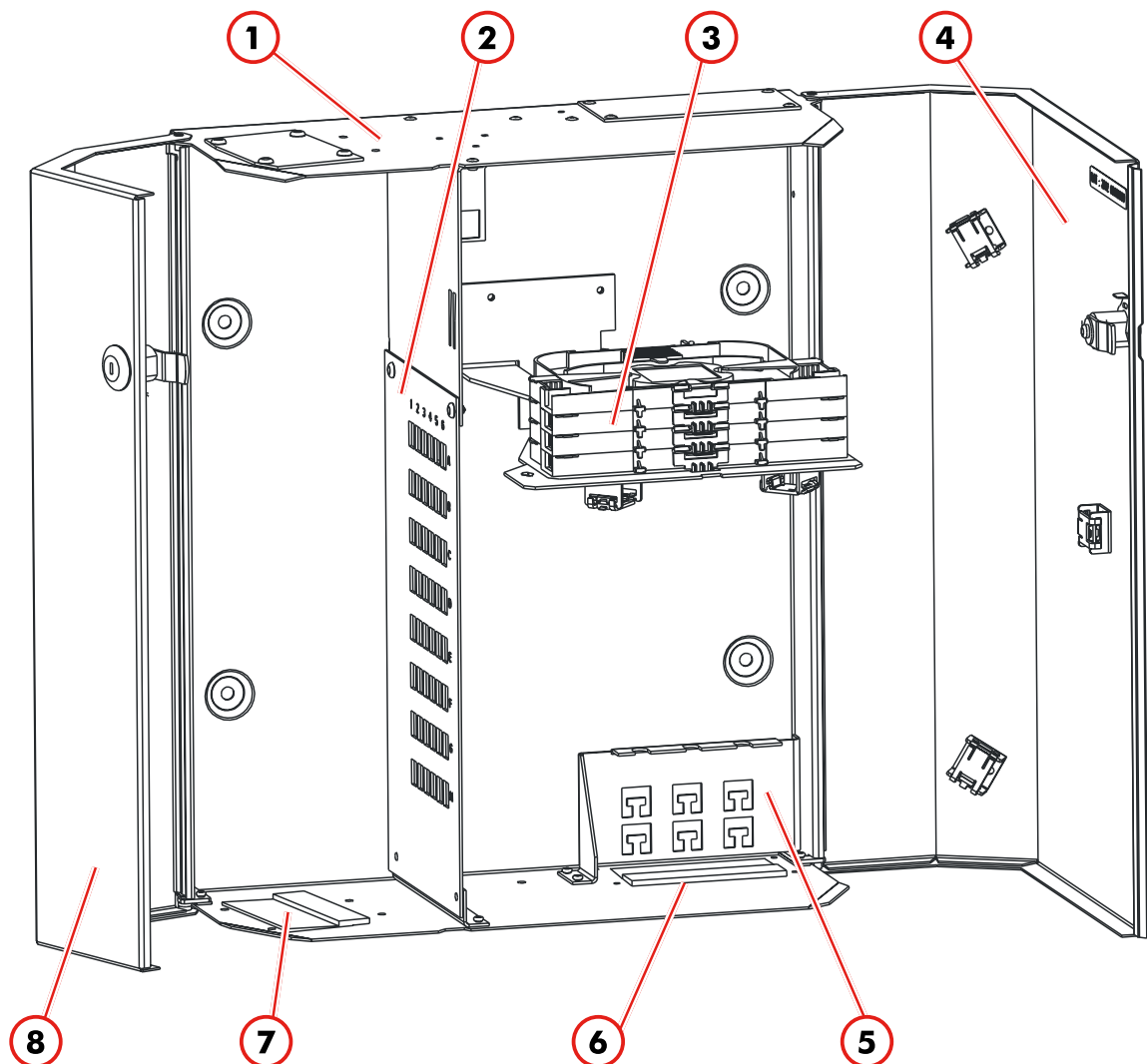

2. FIXATION MURALE WALL FIXING

2.1. Ouverture Opening

- | | |
|-------------------------------------|--|
| 1. Déverrouiller les deux serrures. | 1. <i>Unlock both locks.</i> |
| 2. Ouvrir les deux portes. | 2. <i>Open the doors.</i> |
| 3. Couper le collier de transport. | 3. <i>Cut the transportation collar.</i> |
| 4. Tirer sur le bouton poussoir. | 4. <i>Pull out the latch.</i> |
| 5. Faire basculer l'organiseur. | 5. <i>Swivel the organizer.</i> |

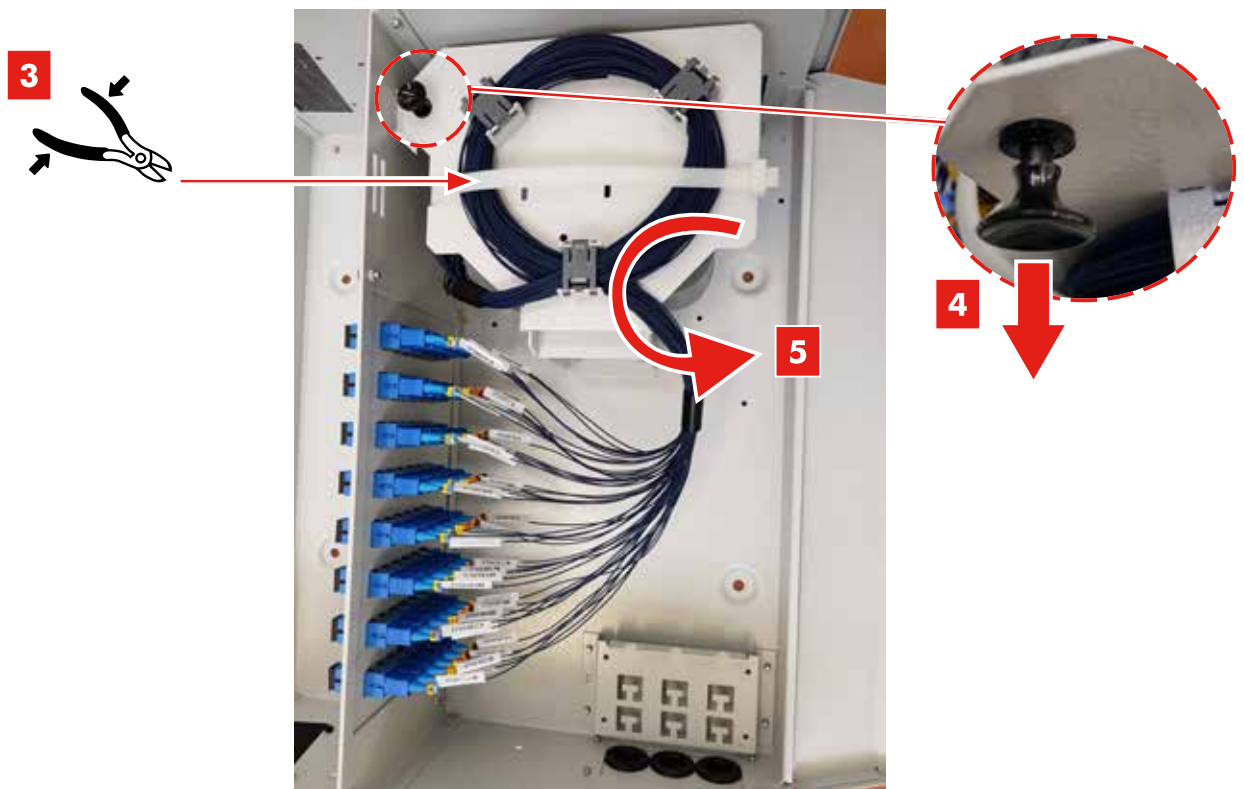
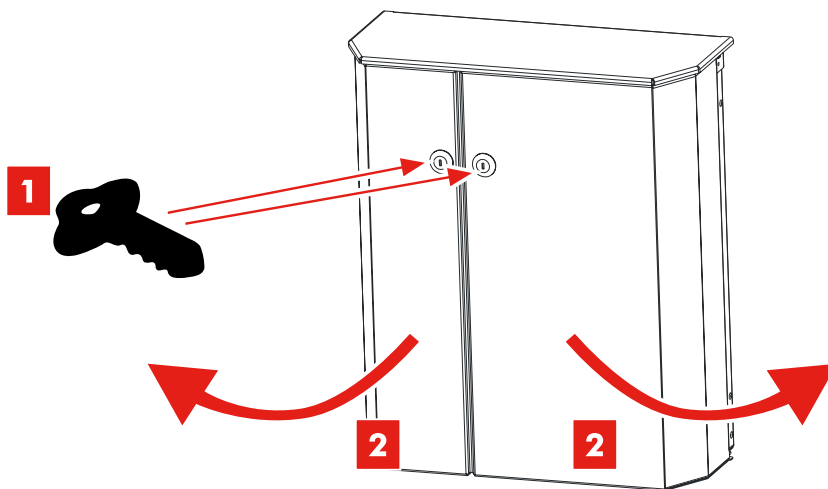

2.2. Fixation
Fixing

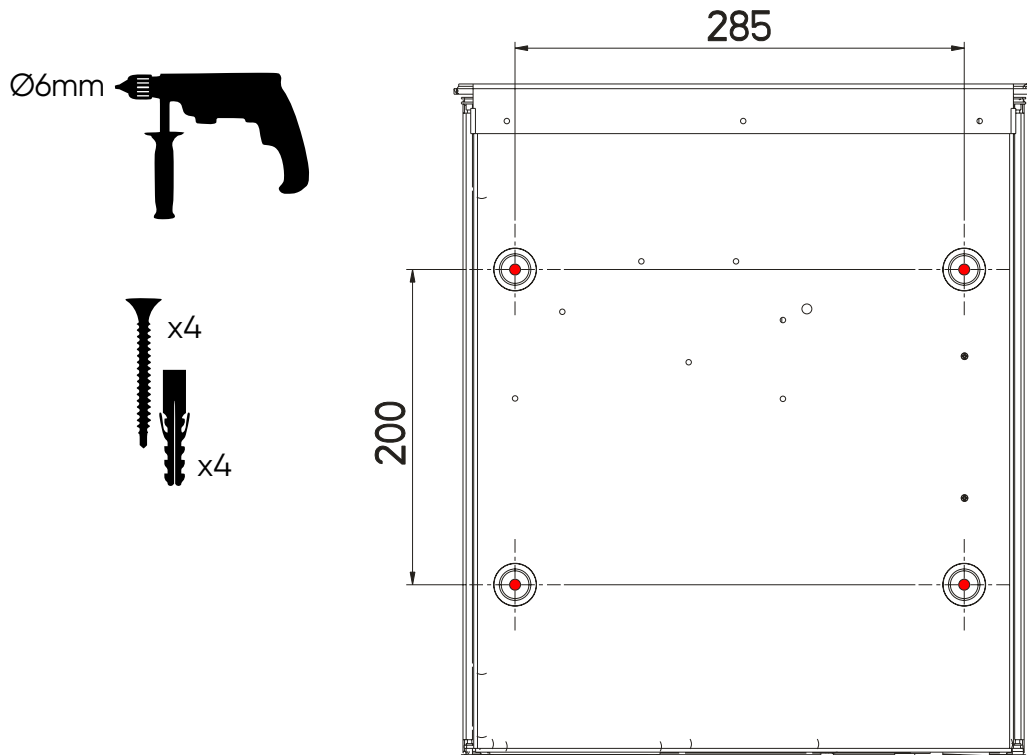

3. **PRÉPARATION DU BOÎTIER**
BOX PREPARATION

3.1. Montage des raccords
Adapters mounting

3.1.1. Montage du panneau de brassage (le cas échéant)
Mounting the patch panel (where appropriate)

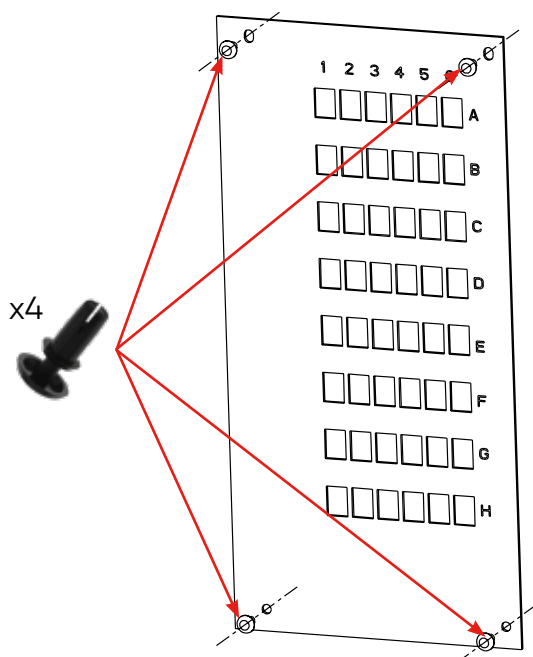

3.1.2. SC / E2000

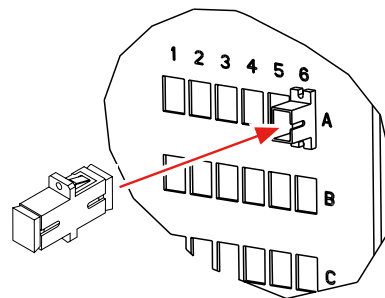

3.1.3. FC

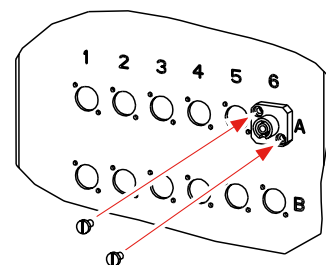

3.2. Montage des kits de gestion des jarretières
Mounting patchcords management kits

1 Choisir les peignes appropriés. *Choose the appropriate combs.*

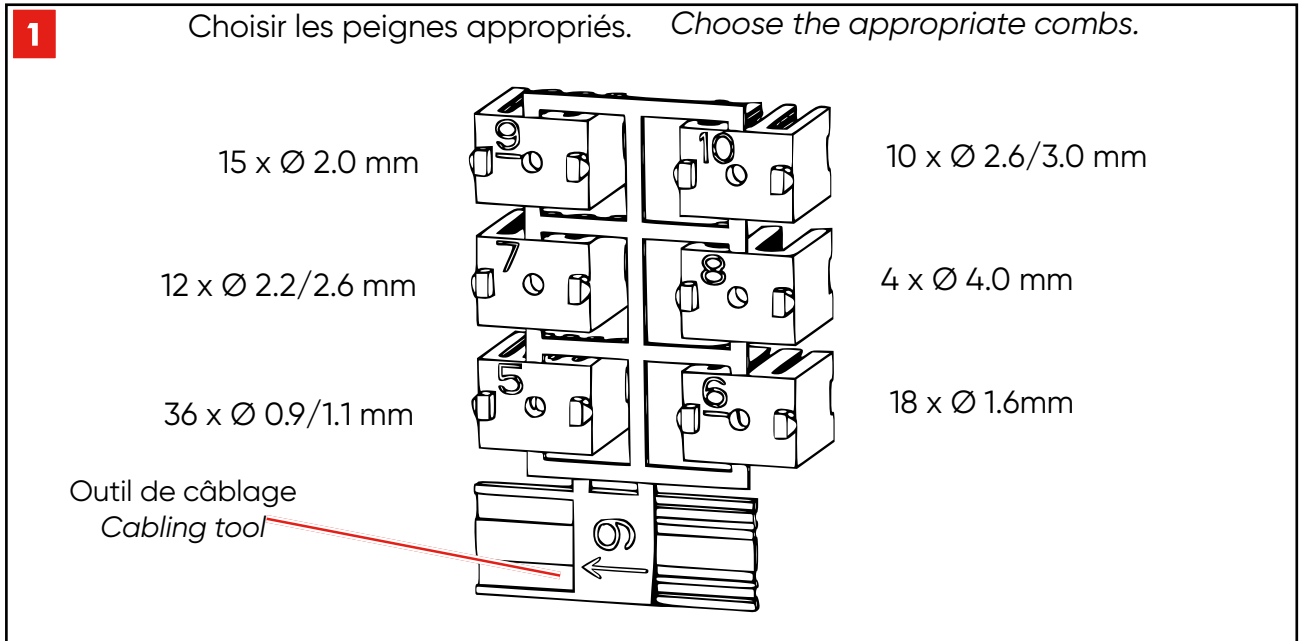

15 x Ø 2.0 mm

10 x Ø 2.6/3.0 mm

12 x Ø 2.2/2.6 mm

4 x Ø 4.0 mm

36 x Ø 0.9/1.1 mm

18 x Ø 1.6mm

Outil de câblage
Cabling tool

2 x4 x4

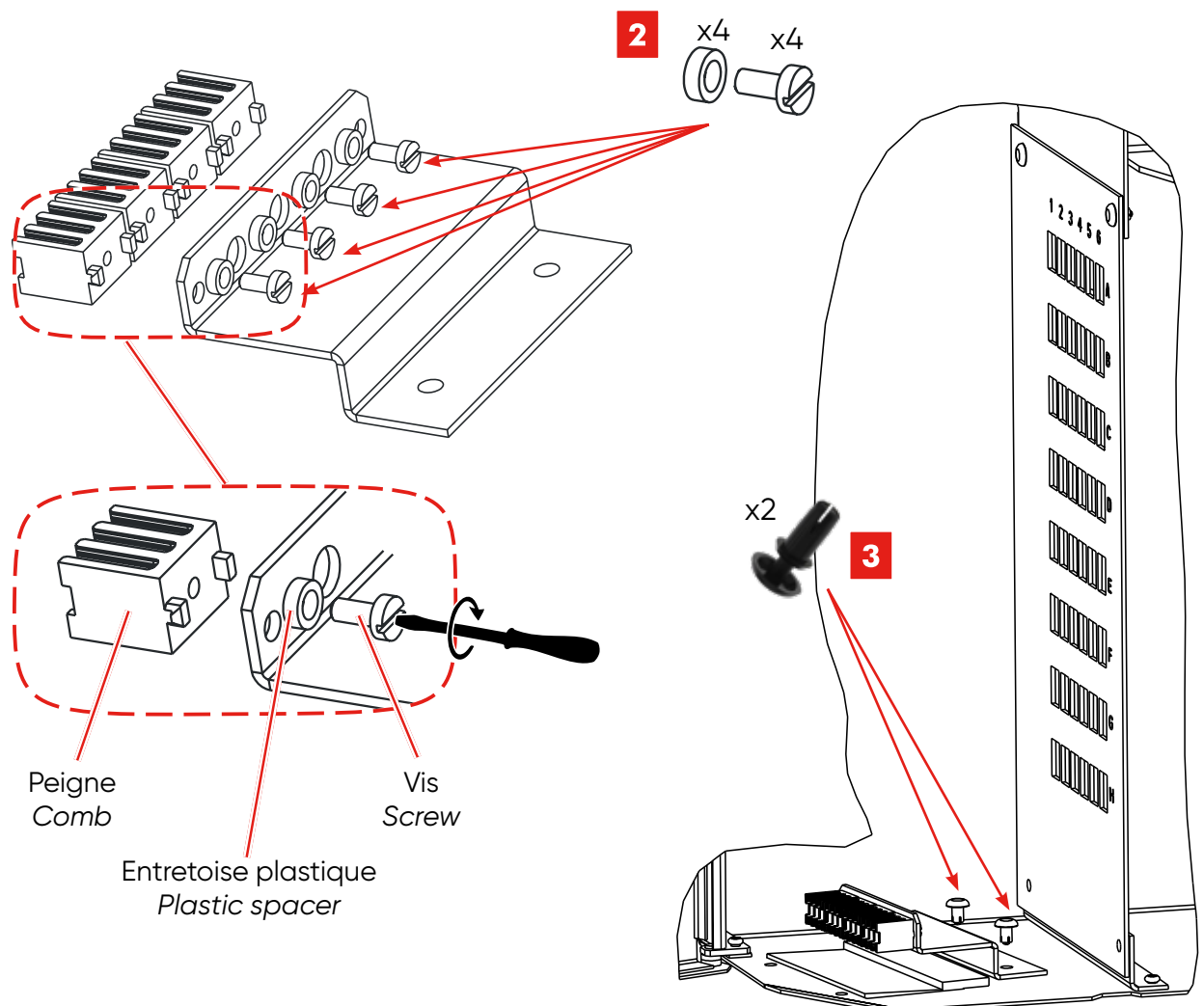

3 x2

Peigne
Comb





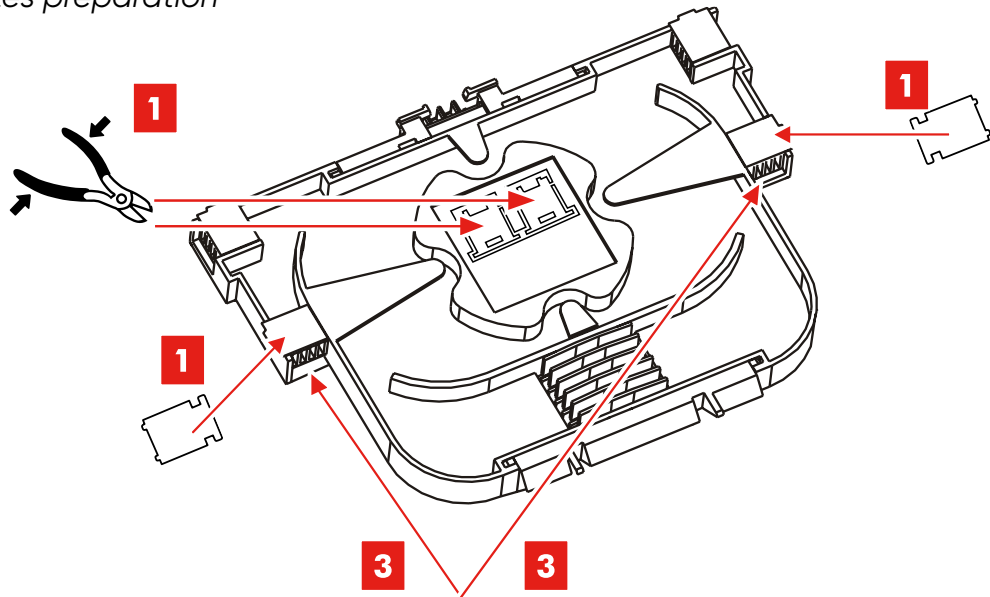

Entretoise plastique
Plastic spacer

Vis
Screw

3.3. Préparation des cassettes
Cassettes preparation

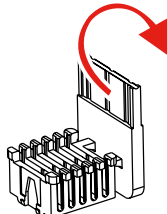

2 Choisir les peignes appropriés. Choose the appropriate combs.

			
6 x Ø 1.6mm	2 x Ø 2.2/2.6 mm	2 x Ø 2.6/3.0 mm	2 x Ø 4.0 mm
	25 x Ø 0.9/1.1 mm		12 x Ø 0.9/1.1 mm

3.4. Installation des pigtails (le cas échéant)
Pigtails installation (where appropriate)

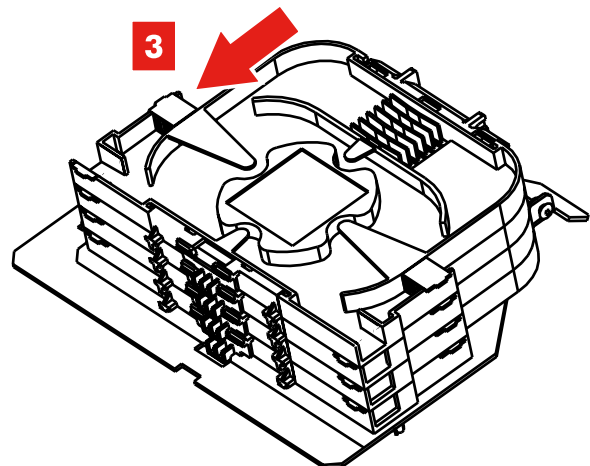

4. MISE EN PLACE DES CÂBLES D'ARRIVÉE INCOMING CABLES INSTALLATION

4.1. Préparation d'un câble en terminaison Terminating cable preparation

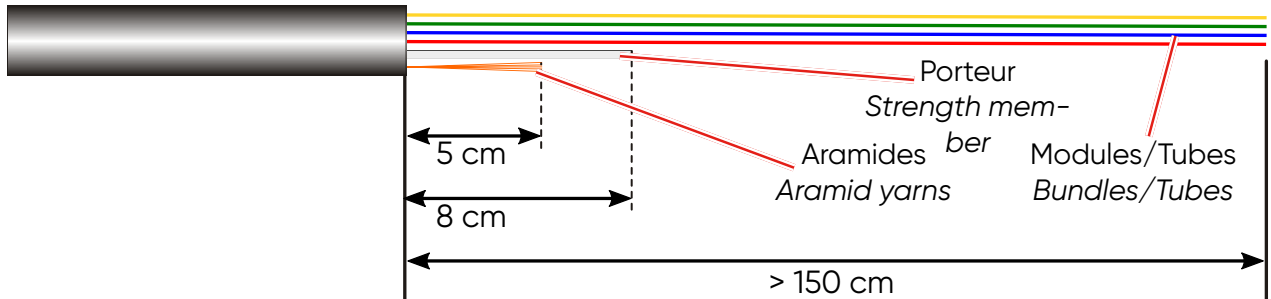

4.2. Préparation d'un câble en piquage Midspan cable preparation

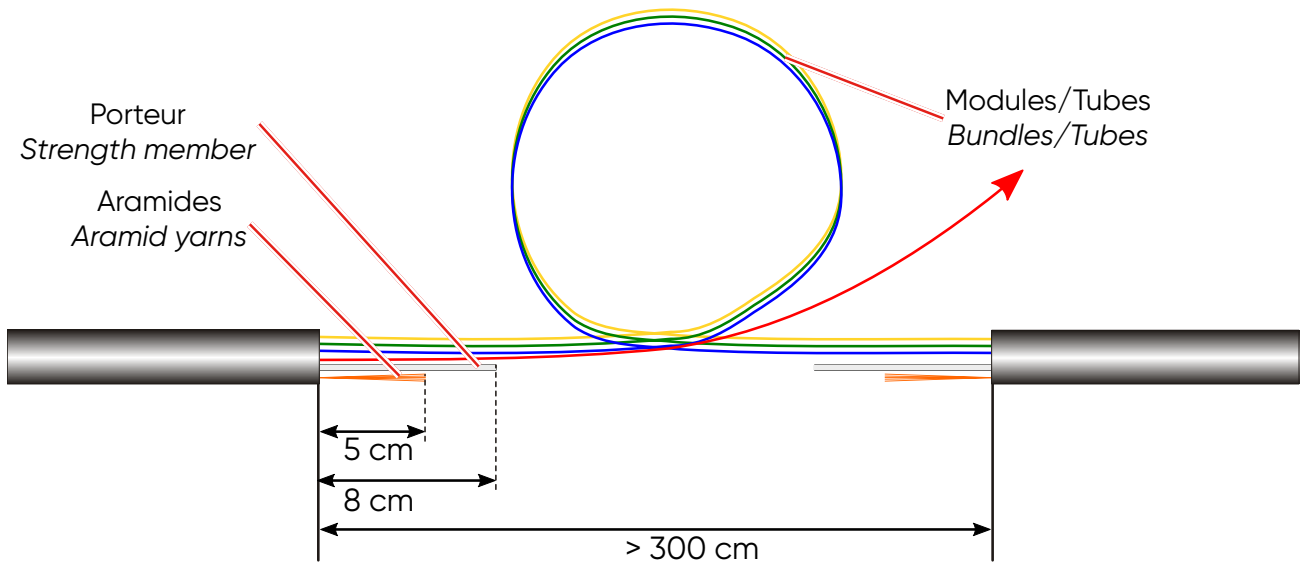

4.3. Arrimage Cable clamping

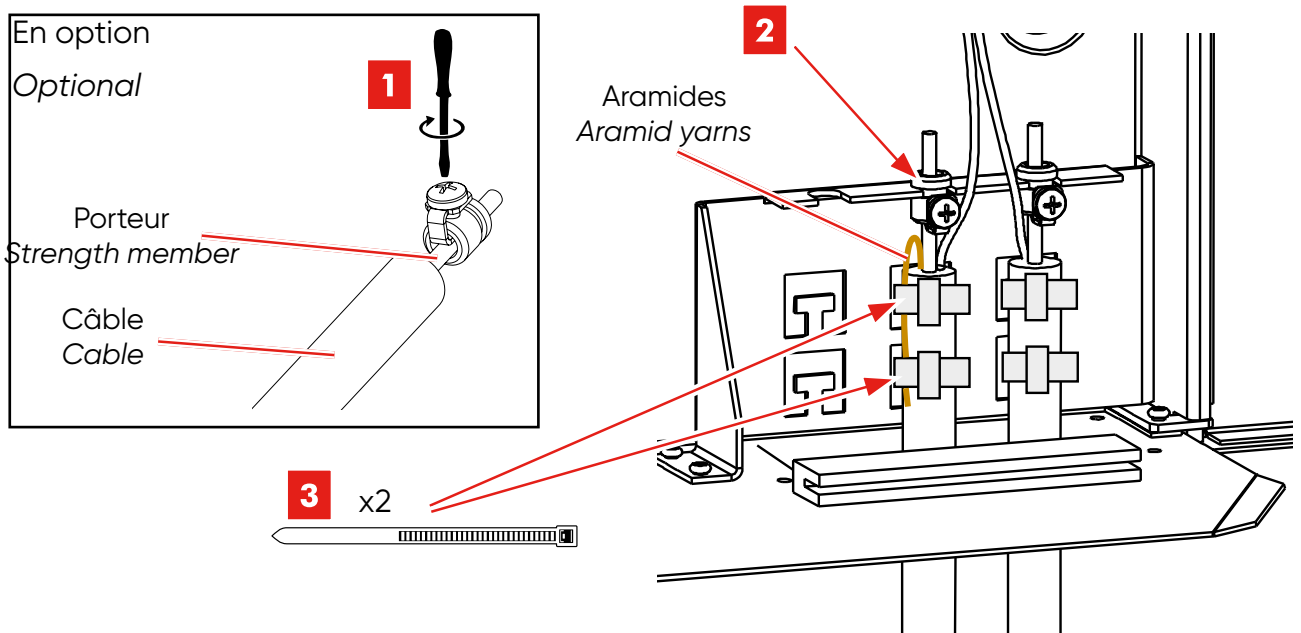

4.4. Acheminement des fibres *Fibres routing*

4.4.1. Entrée de câble par le bas *Bottom cable entrance*

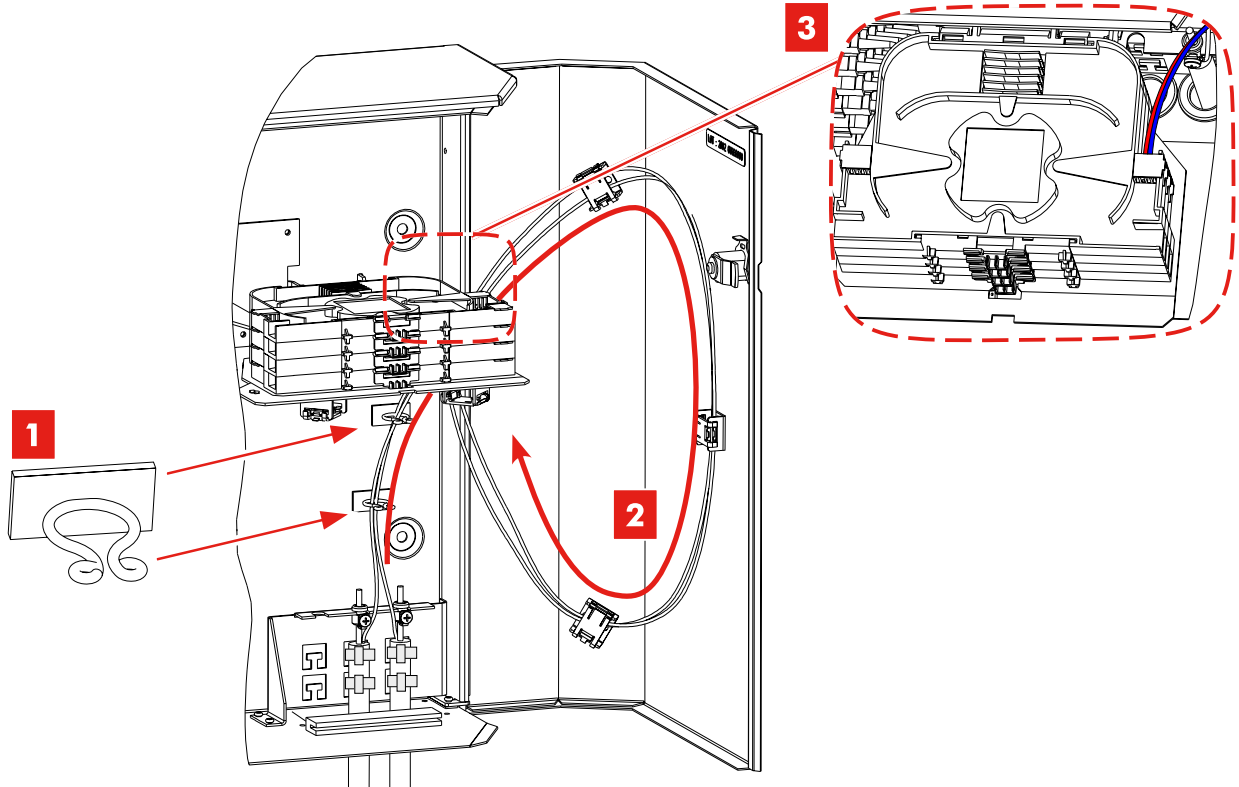

4.4.2. Entrée de câble par le haut *Top cable entrance*

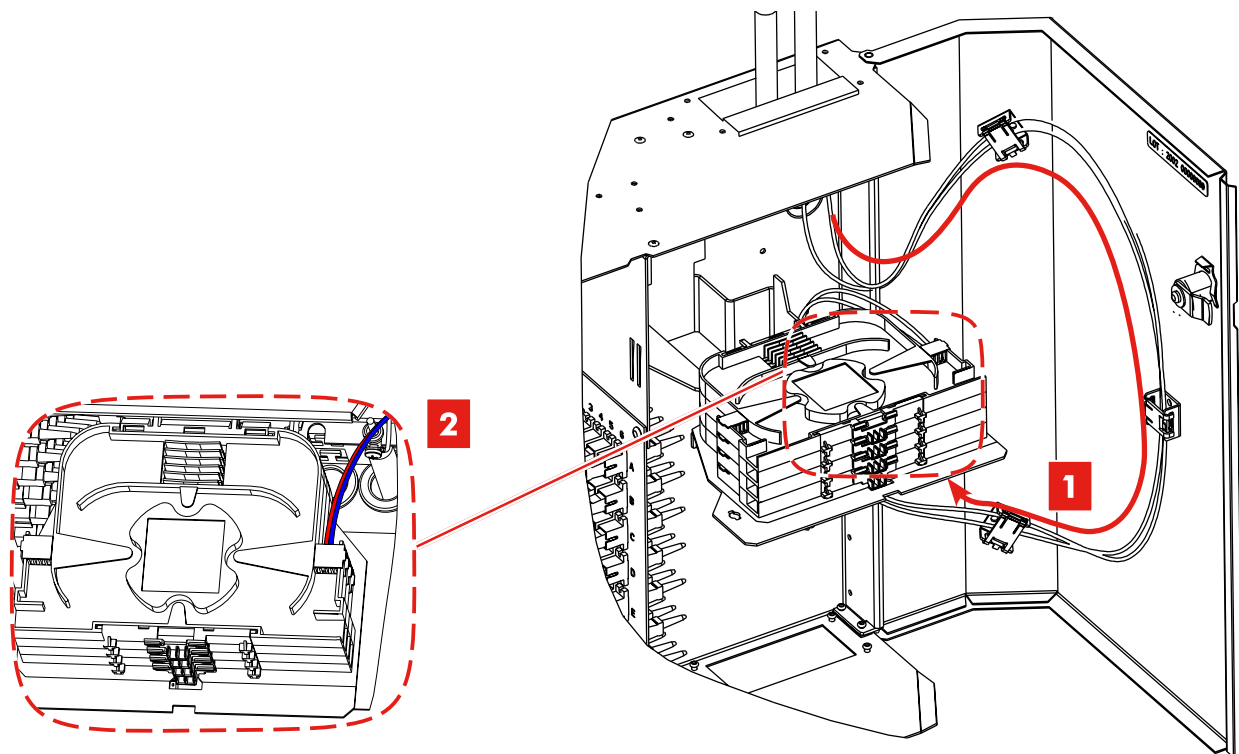

4.5. Epissurage
Splicing

Pigtails
Pigtails

Epissure
Splice

Fibres du câble entrant
Incoming cable fibres

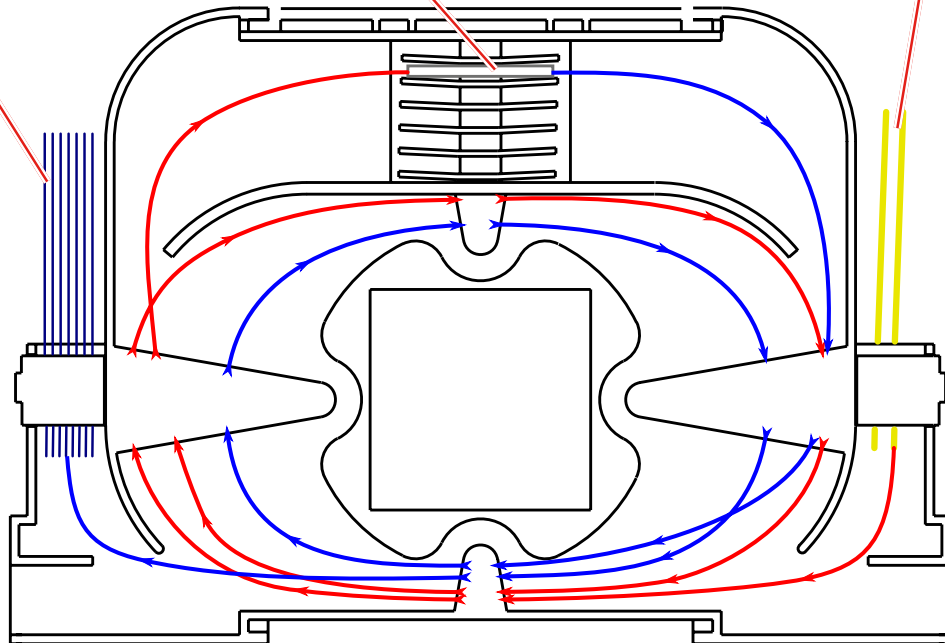

5. MISE EN PLACE DES JARRETIÈRES
PATCHCORDS INSTALLATION

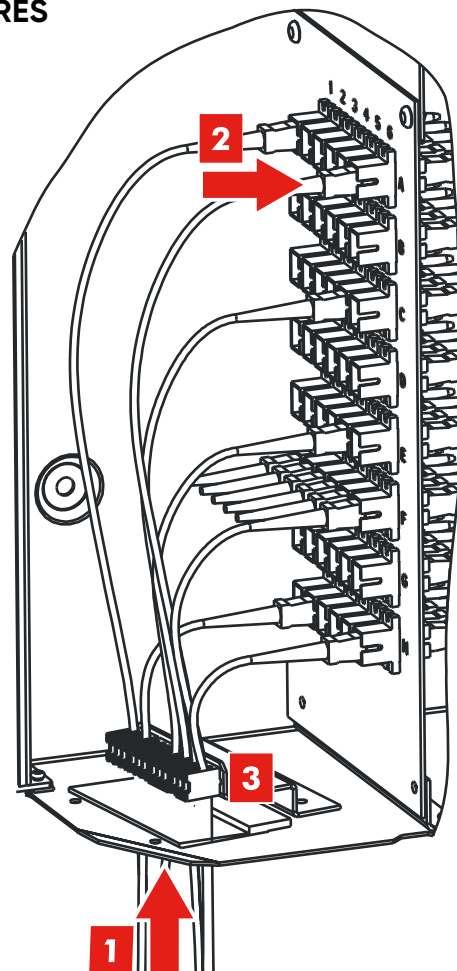

**6. MISE À LA TERRE
EARTHING**

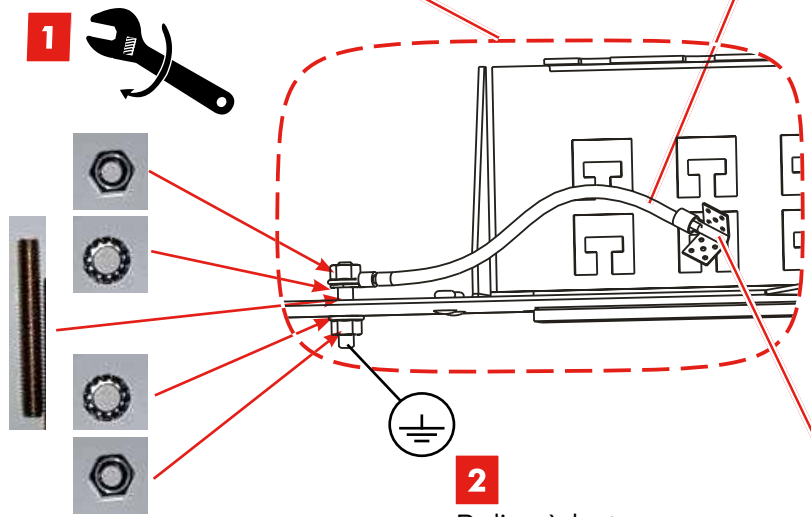
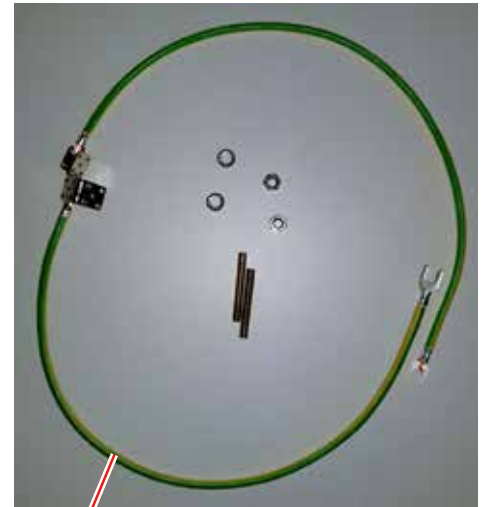
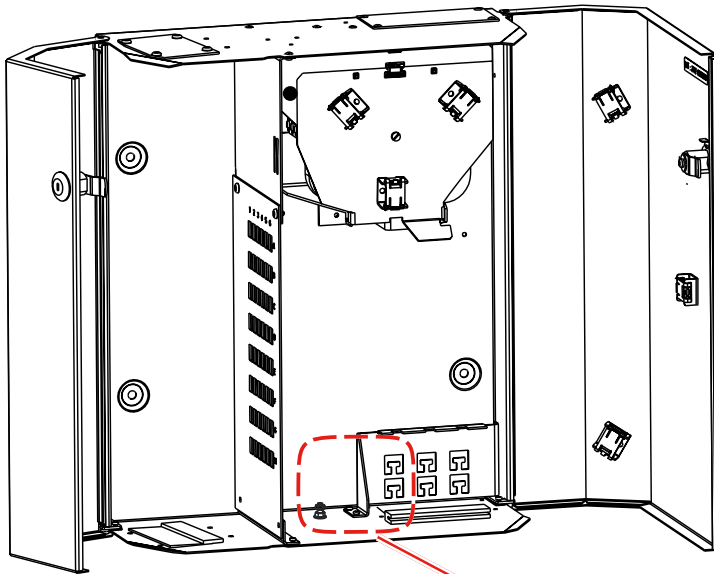

2
Relier à la terre.
Bound to earth.

3
Relier ici l'armature
métallique du câble.
*Bound here the metallic
armour from cable.*

7. INSTRUCTIONS DE FIN DE VIE
END LIFE INSTRUCTIONS



WEEE / DEEE



Pensez à favoriser le réemploi de vos emballages !
Think about reusing your packaging !



Équipement électrique et électronique
Electrical and electronic equipment



Pièce métallique et plastique
Metal and plastic component



Emballage carton, sachet plastique
Cardboard, plastic packaging



Sachet zip réutilisable
Reusable zip bag

Se connecter via LinkedIn
Connect via LinkedIn



En savoir plus sur Youtube
Learn more on YouTube

Visiter www.aginode.net
Visit www.aginode.net

Contactez-nous via
Contact us via
info@aginode.net

AGINODE
1, rue Pierre Viénot
08330 Vrigne-aux-Bois
FRANCE
Tel. +33 (0) 3 24 52 61 61