

# Mechanical closure / WTC0.5

## POLE/WALL MOUNTING BRACKET WTC0.5

**Aginode Ref:** 10085489

The mounting bracket for WTC0.5 allows a closure to be mounted on a wall or pole. Hardware to secure the closure on the bracket is included (metallic stripes for pole mounting optional)

The WTC Splice closures range is designed for enclosing buried, underground, and overhead cable splices.

### Main functions

- To protect splices and bare fibers from the environment and unwanted handlers
- To efficiently and easily store, manage and identify FO splices and fibers.

## Product usage

### Sealing system

- Fully mechanical sealing system for reduced installation and re-entry time.  
The top shell, sealed with a gasket, can be easily installed and removed without special tools or torque control.
- Cable sealing devices based on a mechanical compression system: this allows to re-use all components for future upgrades or re-access to the closure. (No tape, glue, heat-shrink tubes, or cable jacket preparation is needed).  
The mechanical sealing system perfectly fits cables blowing technology.

### Grounding

Standard grounding assures electrical continuity between all cable ports (an external grounding plug is also available).

### Splice management

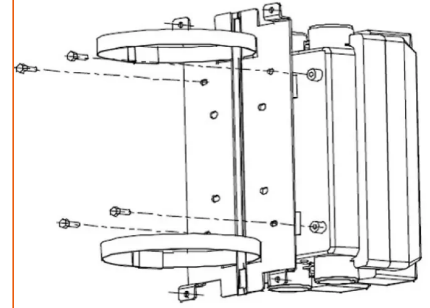

## STANDARDS

Aginode specification

Four plastic splice trays allows to store and identify up to 48 Heat-Shrink splices. Plastic combs for buffer tubes and pigtails retention are integrated in each tray.

### Cabling clamping

WTC0,5 is compatible with the Aginode clamping device range which includes 3 points cable clamps for extremely high cable retention, or simplified 1 point anchoring systems for cables and tubes.

## Characteristics

<b>Material</b>	<b>External:</b> Thermoplastic closure shell ; Stainless Steel screws <b>Internal:</b> Polycarbonate splice trays (V0 - 1.5mm); Zamac or Stainless Steel cable clamp; Stainless Steel trays chassis
<b>Splice capacity</b>	<ul style="list-style-type: none"> <li>• Up to 48 Heat-Shrink splices</li> <li>• 4 Splice trays including moulded plastic combs for buffer tubes and pigtails</li> </ul>
<b>Cable ports</b>	See the <i>Sealing product range datasheet for the number and diameter of cable</i>
<b>Cabling configurations</b>	Straight splicing
<b>Sealing system</b>	<b>Top shell:</b> mechanical sealing (6 Stainless Steel screws – no torque control) <b>Cable ports:</b> WTC mechanical sealing system (elastomer compression)
<b>Grounding</b>	<ul style="list-style-type: none"> <li>• Grounding of all metal components inside the closure.</li> <li>• External grounding plug for hearth connection.</li> </ul>
<b>Dimensions</b>	L: 342mm ;L': 398mm ; W: 110mm ; H: 121.5mm ;I: 245.9mm

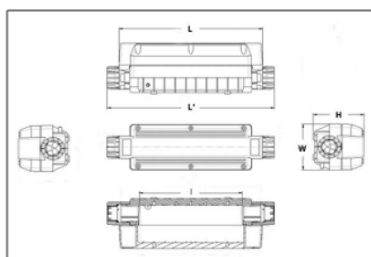

## ドキュメンテーション

Instruction manual pdf – 103.78 KB [ダウンロード ↓](#)