

essential-OF MT LSZH 4-24C - APAC

- Micro Tube optical fiber cable
- Small, but mechanical strong cable
- Designed for splicing with pigtails
- 4-24 fibers

Description and Application

The new Micro Tube technology from Aginode allows to manufacture a flexible and small tube. This Micro Tube is the central part of the new “Essential-OF Micro Tube Cable” design, it contains 4-24 fibers with a fiber diameter of 250 um.

Termination of these fibers is done with splicing with pigtails. Aramid yarns provide additional strength and make the cable installer friendly. The combination of the Micro Tube technology and aramid yarns result in a mechanical robust, but also small and flexible cable. This makes it an optimized cable for datacenters and backbones. The small bending radius of the Essential-OF Micro Tube Cable makes the cable easy to arrange in patch panels, in cable trays and in ducts. The Essential-OF Micro Tube Cable complies with the indoor fire requirements.

Since there is no drip effect of the very limited amount of gel the cable is optimized for both horizontal and vertical installations.

Construction

Legend accompanying the cross-section drawing:

1. Aramid yarn
2. 250um fiber
3. Inner jacket
4. LSZH Outer Jacket

Characteristics

- Micro Tube Cable design for easy installation
- Indoor cable for horizontal and vertical installations
- Fire retardant (IEC 60332-3-24)
- All dielectric design
- Designed for termination by splicing
- Aramid yarns for ease of handling and as strength element
- Available in 4, 6, 8, 12 and 24 fibers

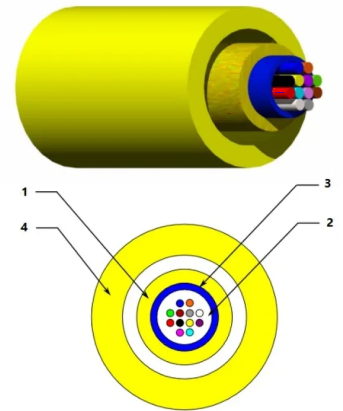

STANDARDS

ANSI/TIA-568-C.3
IEC 60332-1
IEC 60332-3-24 Cat.C
IEC 60793-2-10
ISO/IEC 11801

essential-OF MT LSZH 4-24C - APAC

EIGENSCHAFTEN

Konstruktionsmerkmale

Farbe Orange

Fasertyp OM3 50/125

Abmessungsmerkmale

Aussendurchmesser 3.7 mm

Anzahl der optischen Fasern 6

Mechanische Eigenschaften

Mechanical resistance to impacts (IEC 60794-1-E4) 100 impacts of 1 N.m

Crush resistance (IEC 60794-1-E3) 1000 N/100mm

Max. Zugkraft (IEC 60794-1-2-E1) 440 N

Anwendungsmerkmale

Betriebstemperatur -20...60 °C

Dynamischer Mindestbiegeradius während Anwendung 74.0 mm

Mindestbiegeradius bei statischem Einsatz 37 mm

Lagertemperatur, Bereich -20...60 °C

Umgebungstemperatur, Bereich 0...60 °C

Product list

	Aginode ref.	Country ref.	Name
☎	N275.MT06O	-	essential-OF Micro Tube Cable 6F LSZH Multimode OM3 50/125 Orange
☎	N275.MT08O	-	essential-OF Micro Tube Cable 8F LSZH Multimode OM3 50/125 Orange
☎	N275.MT12O	-	essential-OF Micro Tube Cable 12F LSZH Multimode OM3 50/125 Orange
☎	N275.MT04O	-	essential-OF Micro Tube Cable 4F LSZH Multimode OM3 50/125 Orange
☎	N275.MT24O	-	essential-OF Micro Tube Cable 24F LSZH Multimode OM3 50/125 Orange
☎	N274.MT04Y	-	essential-OF Micro Tube Cable 4F LSZH Single mode OS2 G.652.D 9/125 Yellow
☎	N274.MT06Y	-	essential-OF Micro Tube Cable 6F LSZH Single mode OS2 G.652.D 9/125 Yellow
☎	N274.MT08Y	-	essential-OF Micro Tube Cable 8F LSZH Single mode OS2 G.652.D 9/125 Yellow
☎	N274.MT12Y	-	essential-OF Micro Tube Cable 12F LSZH Single mode OS2 G.652.D 9/125 Yellow
☎	N274.MT24Y	-	essential-OF Micro Tube Cable 24F LSZH Single mode OS2 G.652.D 9/125 Yellow

☎ = Make to order, 🏠 = In Stock