

Document : ABS1555/D  
Date : 07/05/2024



#smartconnection

NOTICE / INSTRUCTIONS



## Armoire / Cabinet

Armoire de distribution 24/48  
24/48 distribution cabinet

[www.aginode.net](http://www.aginode.net)



# Table des matières

## Table Of Contents

<b>1. DESCRIPTION</b>	
<b>OVERVIEW</b> .....	<b>4</b>
1.1. PRÉSENTATION DU BOÎTIER	
BOX OVERVIEW.....	4
1.2. CARACTÉRISTIQUES TECHNIQUES	
TECHNICAL CHARACTERISTICS.....	5
1.3. KITS FOURNIS ET PEIGNES	
PROVIDED KITS AND COMBS.....	6
1.4. PRÉSENTATION DE LA CASSETTE	
CASSETTE OVERVIEW.....	8
<b>2. OPÉRATIONS PRÉLIMINAIRES</b>	
<b>INITIAL OPERATIONS</b> .....	<b>9</b>
2.1. OUVERTURE DU BOÎTIER	
OPENING THE BOX.....	9
2.2. FIXATION MURALE (VOIR PAGE 6)	
WALL MOUNTING (SEE PAGE 6).....	9
2.3. FIXATION SUR UN POTEAU (VOIR PAGE 6)	
POLE MOUNTING (SEE PAGE 6).....	10
2.4. FIXATION SUR UN SOCLE EN BÉTON (VOIR PAGE 6)	
MOUNTING ON THE CONCRETE BASE (SEE PAGE 6).....	11
<b>3. PRÉPARATION DU BOÎTIER</b>	
<b>PREPARATION OF THE BOX</b> .....	<b>12</b>
3.1. MISE EN PLACE DES RACCORDES	
INSTALLATION OF THE ADAPTERS.....	12
3.2. MISE EN PLACE DU KIT COUPLEUR (VOIR PAGE 6)	
INSTALLATION OF THE SPLITTER KIT (SEE PAGE 6).....	12
3.3. CLIPPER LES ANNEAUX DE GESTION DES CÂBLES	
FIXATION OF THE COILING GUIDES CABLES.....	13
3.4. MISE EN PLACE DU KIT D'ENTRÉE ET DE SORTIE DE CÂBLE	
INSTALLATION OF THE INPUT AND OUTPUT CABLE KIT.....	13
3.5. PRÉPARATION DES CASSETTES	
PREPARATION OF THE CASSETTES.....	15
<b>4. CÂBLAGE CÔTÉ ENTRÉE DU RÉSEAU</b>	
<b>WIRING ON THE INPUT SIDE NETWORK</b> .....	<b>16</b>
4.1. ZONE DE RACCORDEMENT RÉSEAU	
NETWORK CONNECTING AREA.....	16
4.2. INSTALLATION DU CÂBLE RÉSEAU	
INSTALLATION OF THE NETWORK CABLE.....	17

## Table des matières

<b>5.</b>	<b>RACCORDEMENT DES ABONNÉS</b> <b>CONNECTING THE SUBSCRIBERS</b> .....	<b>21</b>
5.1.	ZONE DE RACCORDEMENT ABONNÉS SUBSCRIBERS CONNECTING AREA.....	21
5.2.	INSTALLATION DU CÂBLE ABONNÉS INSTALLATION OF THE SUSCRIBER CABLE.....	22
<b>6.</b>	<b>FERMETURE DU BOÎTIER</b> <b>CLOSING THE BOX</b> .....	<b>24</b>
<b>7.</b>	<b>INSTRUCTIONS DE FIN DE VIE</b> <b>END LIFE INSTRUCTIONS</b> .....	<b>25</b>

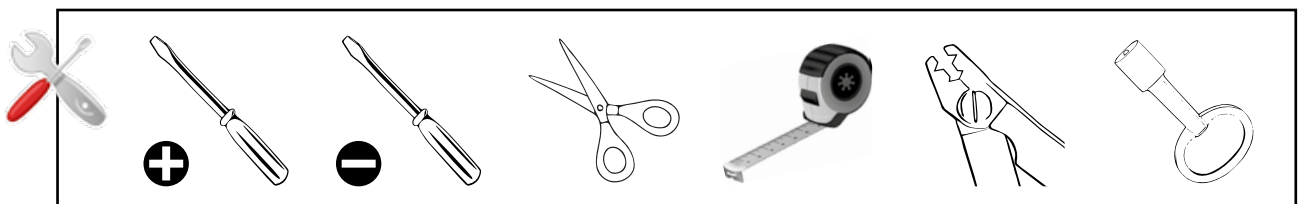

## 1. DESCRIPTION OVERVIEW

### 1.1. Présentation du boîtier Box overview

- |     |                             |     |                            |
|-----|-----------------------------|-----|----------------------------|
| 1-  | T d'arrimage                | 1-  | Clamping kit               |
| 2-  | Anneau de lovage            | 2-  | Coiling ring               |
| 3-  | Support coupleurs           | 3-  | Splitters holder           |
| 4-  | Panneau de brassage         | 4-  | Patch panel                |
| 5-  | Anneau de lovage            | 5-  | Coiling ring               |
| 6-  | Levier de blocage           | 6-  | Lock lever                 |
| 7-  | Zone de parking             | 7-  | Parking area               |
| 8-  | Organiseur 4 ou 8 cassettes | 8-  | Organiser 4 or 8 cassettes |
| 9-  | Joints ou brosse            | 9-  | Seals or brush             |
| 10- | Entrée câble réseau         | 10- | Network cable entry        |
| 11- | Boîtier                     | 11- | Box                        |

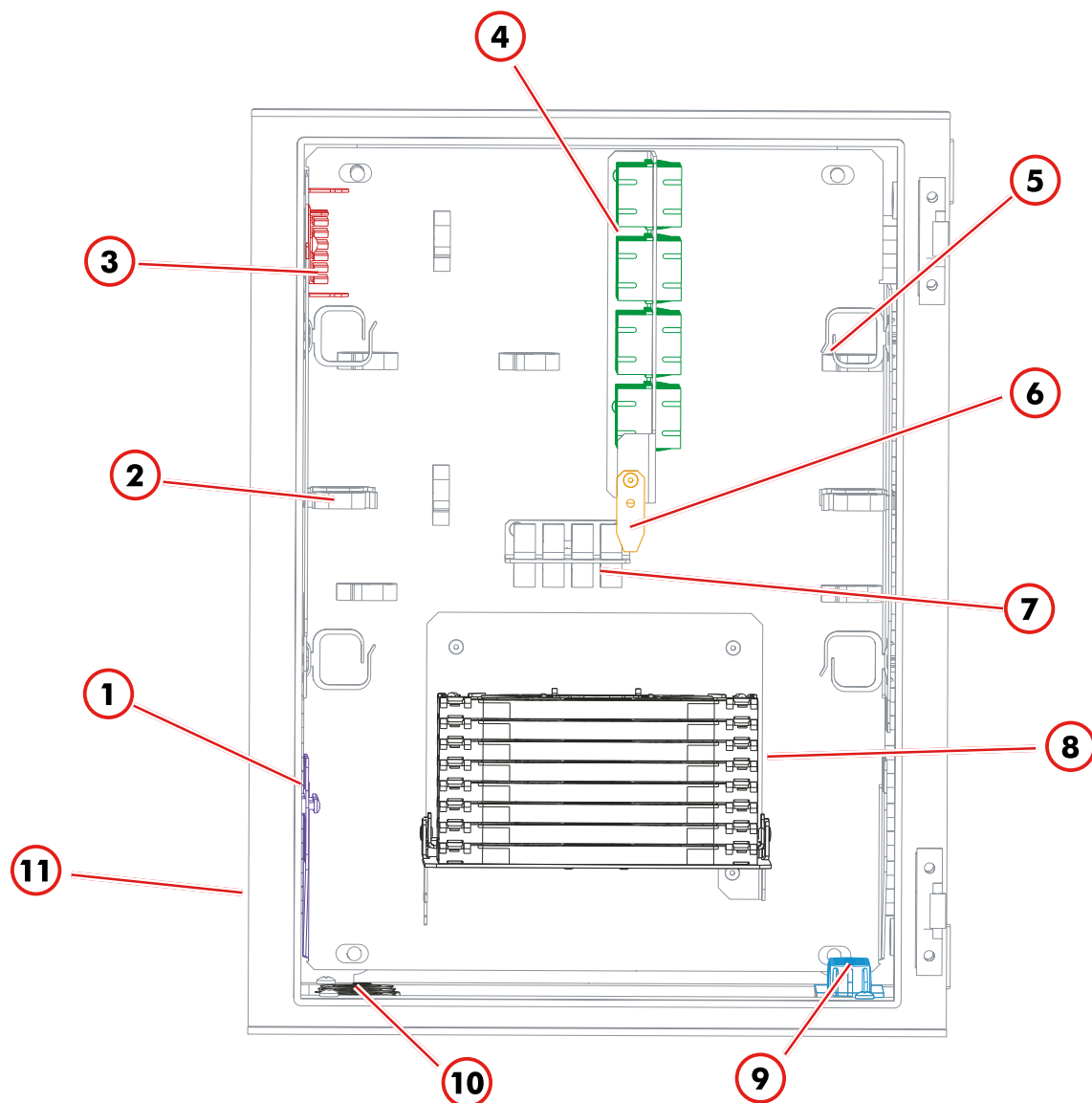





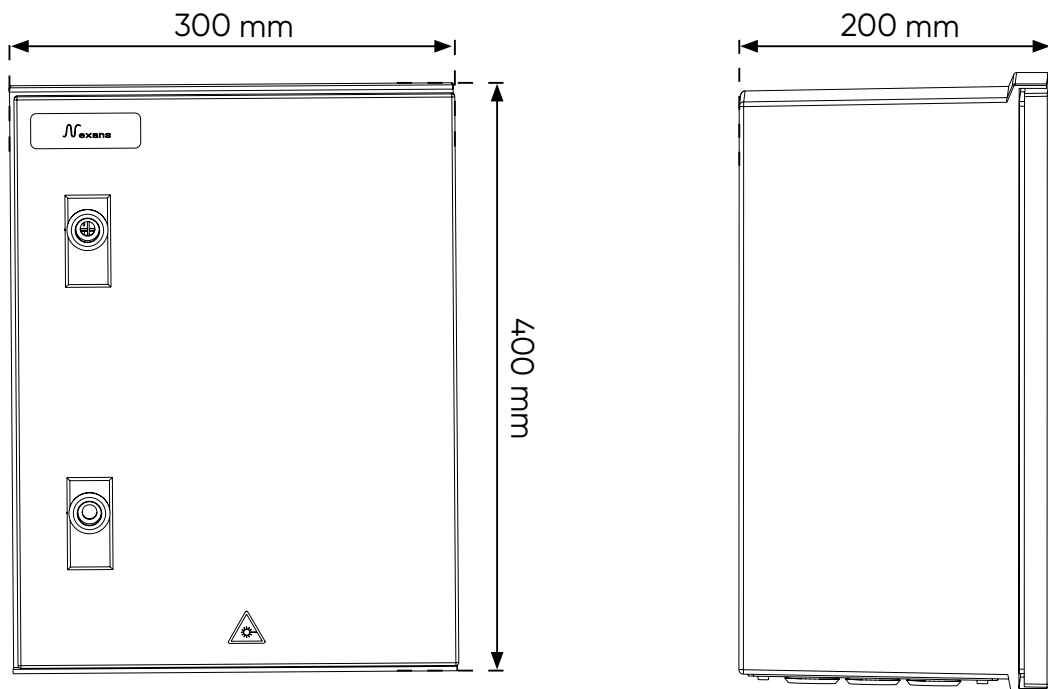

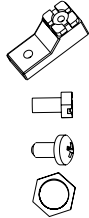

## 1.2. Caractéristiques techniques *Technical characteristics*

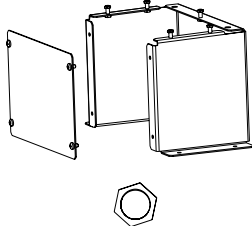
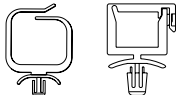
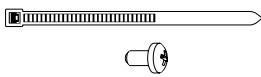
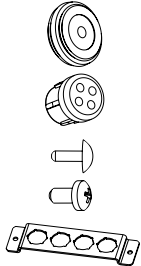
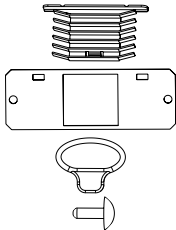

- |                    |       |                   |       |
|--------------------|-------|-------------------|-------|
| – Poids (à vide) : | 6,3kg | – Weight (empty): | 6.3kg |
| – Hauteur :        | 400mm | – Height:         | 400mm |
| – Largeur :        | 300mm | – Width:          | 300mm |
| – Profondeur :     | 200mm | – Depth:          | 200mm |



## 1.3. Kits fournis et peignes *Provided Kits and combs*

	Description	Qté / Qty
Kit de fixation murale : – Supports de fixation – Vis hexagonale – Vis standard – Écrous		<i>Wall mounting kit:</i> – Mounting brackets <b>4</b> – Hexagonal screws <b>8</b> – Standard screws <b>4</b> – Nuts <b>4</b>
Kit de fixation sur poteau : – Équerres de fixation – Rails en C – Cerclage métallique – Vis hexagonale – Écrous		<i>Pole mounting kit:</i> – Mounting brackets <b>4</b> – C rails <b>2</b> – Metallic strapping <b>2</b> – Hexagonal screws <b>8</b> – Nuts <b>4</b>
Kit de fixation sur socle en béton : – Réhausse métallique – Plaque avant métallique – Vis hexagonale – Vis standard – Écrous		<i>Concrete base mounting kit:</i> – Metallic riser <b>1</b> – Metallic front plate <b>1</b> – Hexagonal screws <b>5</b> – Screws <b>4</b> – Nuts <b>5</b>
Kit de guidage des câbles : – Anneaux de lovage		<i>Cables routing kit:</i> – Coiling rings <b>15</b>
Kit d'arrimage : – Colliers plastique – Vis		<i>Clamping kit:</i> – Plastic ties <b>12</b> – Screws <b>6</b>
Kit d'entrée et de sortie de câble : – Passe câbles à étages – Joints 4 trous – Rivets plastique – Vis en inox – Plaque métallique		<i>Input and output cable kit:</i> – Plugs <b>3</b> – 4-hole seals <b>4</b> – Plastic rivets <b>2</b> – Inox screws <b>4</b> – Metallic plates <b>2</b>
Kit coupleur : (EUROPE) – Support coupleurs – Plaque métallique – Élastique – Rivets plastique		<i>Splitter kit:</i> – Splitters holder <b>1</b> – Metallic plate <b>1</b> – Elastic <b>1</b> – Plastic rivets <b>2</b>

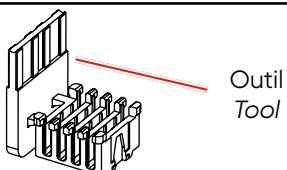
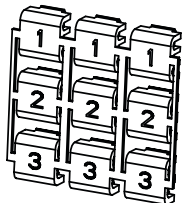
Description		Qté / Qty
Kit d'entrée et sortie de câble :		
- Passe câble à étage		<b>3</b>
- Brosse		<b>1</b>
- Vis en inox		<b>4</b>
Kit coupleur : (ASIE)		
- Plaque métallique		<b>1</b>
- Elastique		<b>1</b>
- Rivets plastique		<b>2</b>

Numéro du peigne Comb number		Ø des tubes ou pigtails Ø of tubes or pigtails	Qté / Qty
Peigne plastique Plastic comb		Ø 900µm	<b>16</b>
Peigne plastique #1 #2 #3 Plastic comb #1 #2 #3		Ø 1.6mm Ø 2.4mm Ø 2.8mm	<b>3</b> <b>3</b> <b>3</b>
Peigne plastique #5 Plastic comb #5		Ø 5mm	<b>8</b>

## 1.4. Présentation de la cassette *Cassette overview*

Grande cassette :

- Mise en place des supports d'épissures de longueur 60mm max.
- Lovage des surlongueurs de fibres Ø 250µm

*Large cassette:*

- *Installation of max 60mm max long splice supports*
- *Coiling of Ø 250µm fibres overlengths*



Capacité maximale :  
12 épissures, fibre G.652.D  
*Max. capacity:*  
*12 splices, G.652.D fibre*

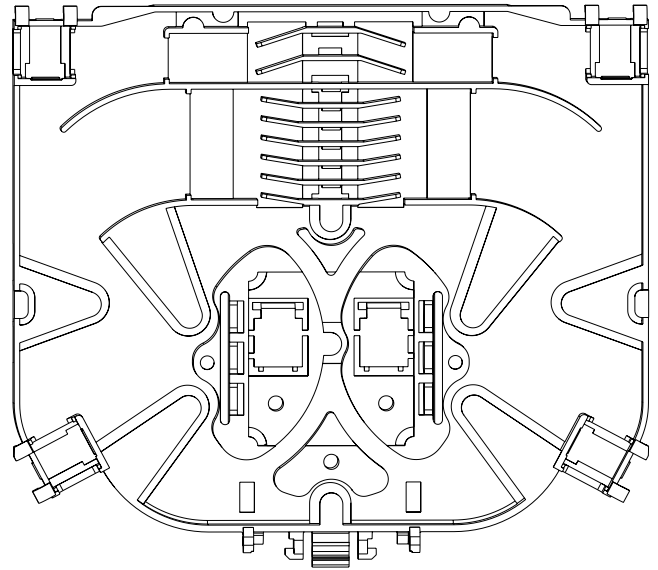



## 2. OPÉRATIONS PRÉLIMINAIRES INITIAL OPERATIONS

### 2.1. Ouverture du boîtier Opening the box

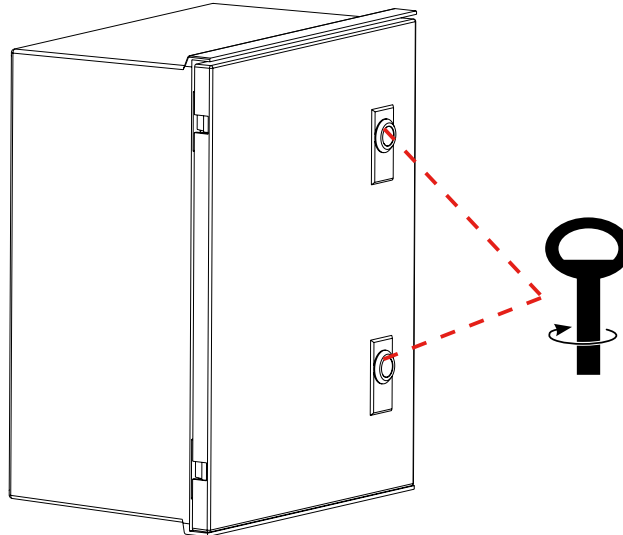

### 2.2. Fixation murale (voir page 6) Wall mounting (see page 6)

- |   |   |
|---|---|
| <ol style="list-style-type: none"> <li>1. Retirer la plaque de fond du boîtier</li> <li>2. Percer quatre trous à l'arrière du boîtier</li> <li>3. Viser les supports de fixation (vis hexagonale + écrou)</li> <li>4. Remettre la plaque de fond du boîtier</li> <li>5. Fixer le boîtier sur le mur (vis standard)</li> </ol> | <ol style="list-style-type: none"> <li>1. Remove the base plate of the box</li> <li>2. Drill 4 holes at the back of the box</li> <li>3. Fixing the mounting brackets (hexagonal screw + nuts)</li> <li>4. Installing the base plate in the box</li> <li>5. Fixing the box on the wall (standard screw)</li> </ol> |
|---|---|

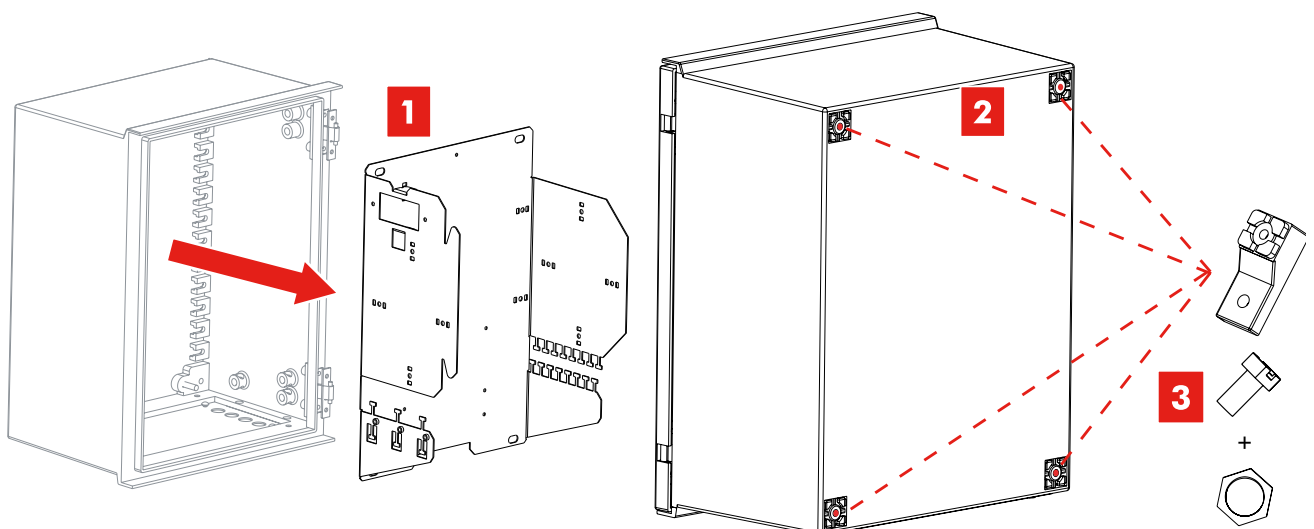

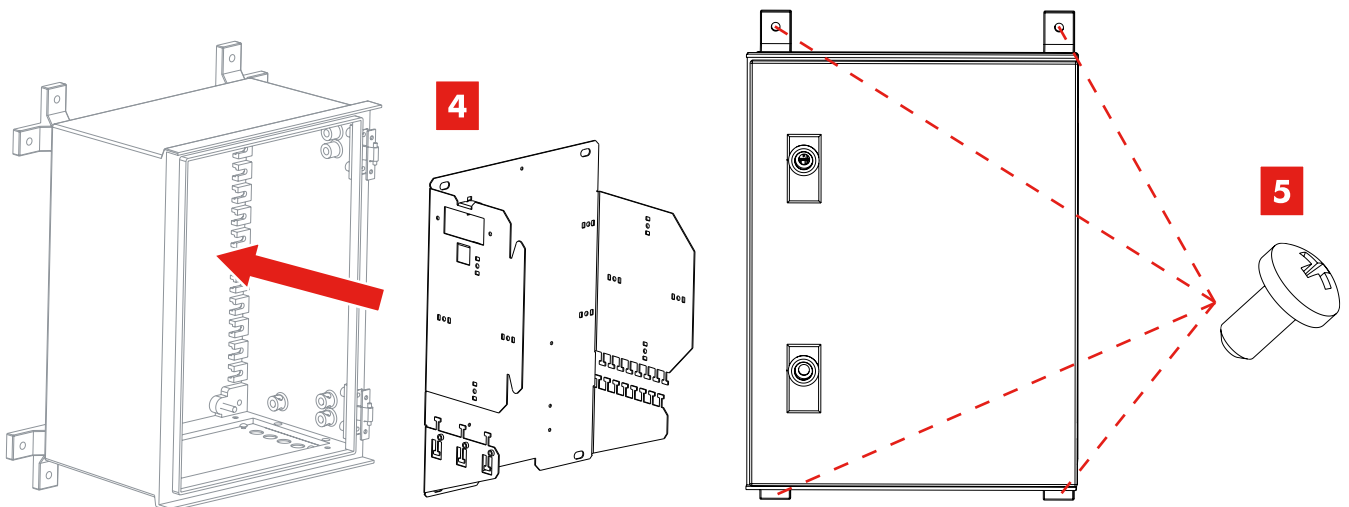

## 2.3. Fixation sur un poteau (voir page 6) *Pole mounting (see page 6)*

- |   |   |
|---|---|
| <ol style="list-style-type: none"> <li>1. Retirer la plaque de fond du boîtier</li> <li>2. Percer quatre trous à l'arrière du boîtier</li> <li>3. Viser les supports de fixation</li> <li>4. Remettre la plaque de fond du boîtier</li> <li>5. Mettre le rail supérieur avec le collier métallique sur le poteau et serrer en laissant un jeu permettant l'ajustement</li> <li>6. Fixer le boîtier sur le rail supérieur</li> <li>7. Fixer le rail inférieur avec le collier en l'ajustant aux équerres de fixation libres</li> <li>8. Serrer les colliers supérieures et inférieurs</li> </ol> | <ol style="list-style-type: none"> <li>1. Remove the base plate of the box</li> <li>2. Drill 4 holes at the back of the box</li> <li>3. Screw the fixing brackets</li> <li>4. Installing the base plate in the box</li> <li>5. Put the top rail with the metallic strapping on the pole and slightly tighten allowing future adjustment</li> <li>6. Fixing the box on top rail</li> <li>7. Fixing the lower rail with the strapping adjusting to the free fixing brackets</li> <li>8. Tightly tighten upper and lower strappings</li> </ol> |
|---|---|

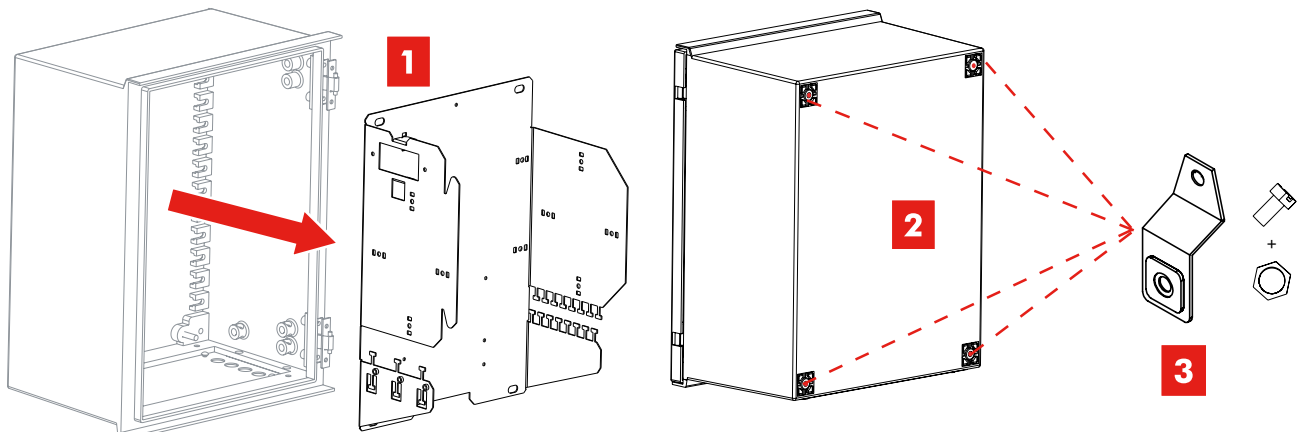

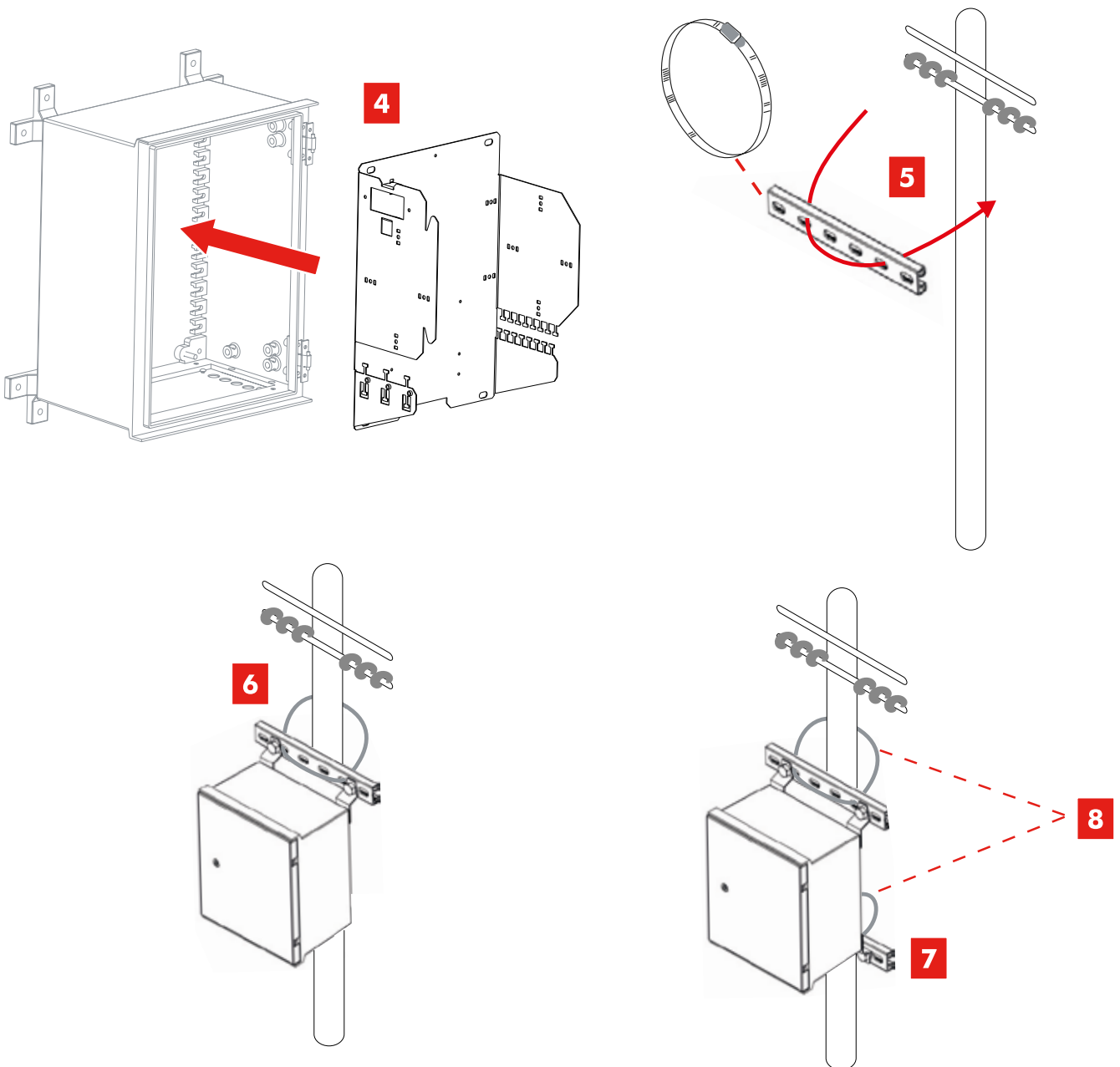

2.4. Fixation sur un socle en béton (voir page 6)  
*Mounting on the concrete base (see page 6)*

Se référer à la notice « Réhausse de l'armoire de distribution » fournie conjointement.

*Refer to the notice « distribution cabinet metallic riser » provided jointly.*



Les supports de fixation peuvent être placés horizontalement ou verticalement selon le support.

*The mounting brackets can be placed horizontally or vertically depending on the support.*

### 3. PRÉPARATION DU BOÎTIER *PREPARATION OF THE BOX*

#### 3.1. Mise en place des raccords *Installation of the adapters*

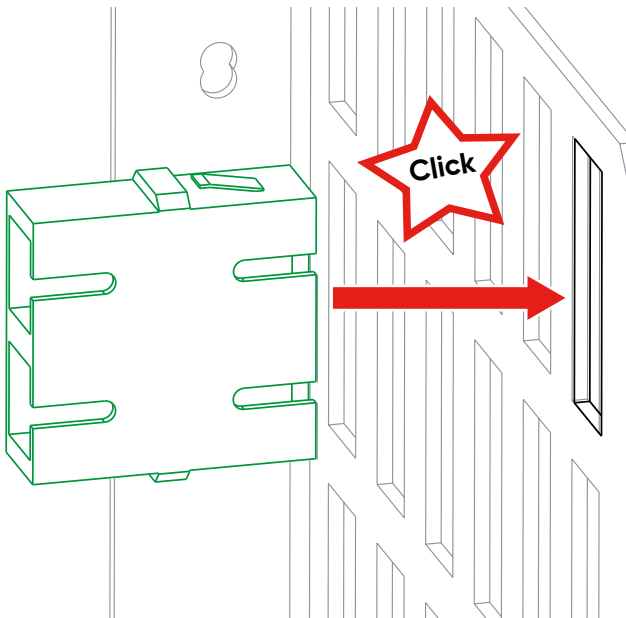

#### 3.2. Mise en place du kit coupleur (voir page 6) *Installation of the splitter kit (see page 6)*

1. Assembler la plaque métallique et le support coupleur
2. Fixer l'assemblage avec les deux rivets plastiques (en haut à gauche du boîtier)

1. Join the metallic plate and the splitter holder
2. Fixing the assembly with the two plastics rivets (on the top left of the box)

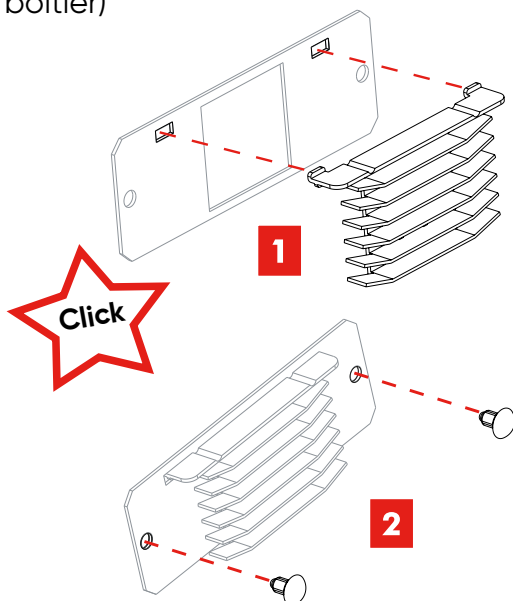

### 3.3. Clipper les anneaux de gestion des câbles *Fixation of the coiling guides cables*

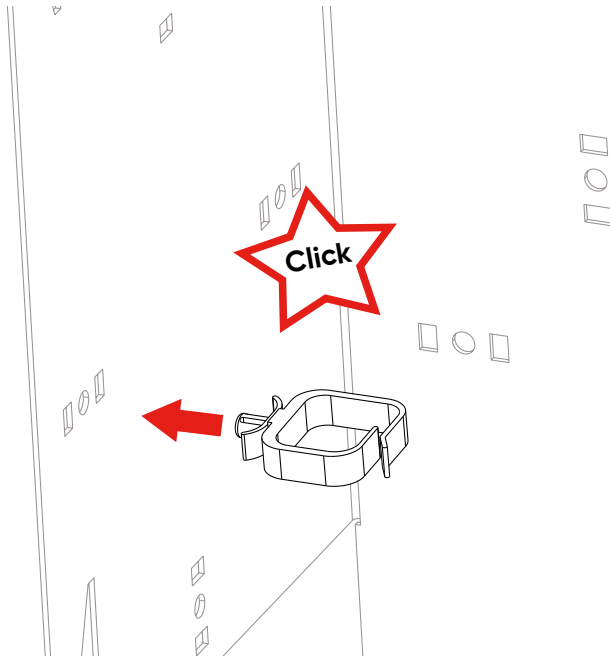

### 3.4. Mise en place du kit d'entrée et de sortie de câble *Installation of the input and output cable kit*

1. Mise en place des joints 4 trous
2. Installation des passes câbles à étages
3. Installation de la brosse

1. Installation of 4-hole seals
2. Installation of the plugs
3. Installation of the brush

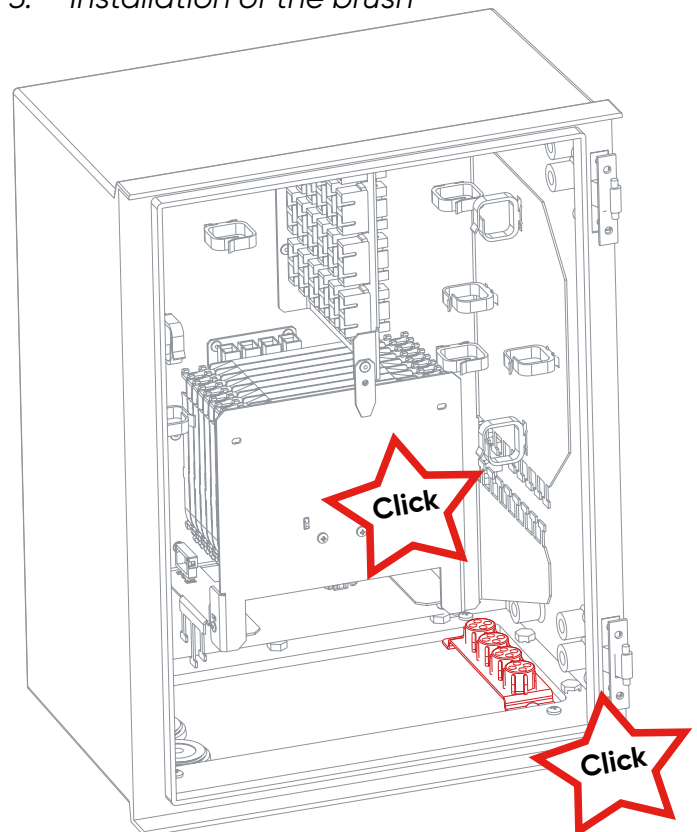
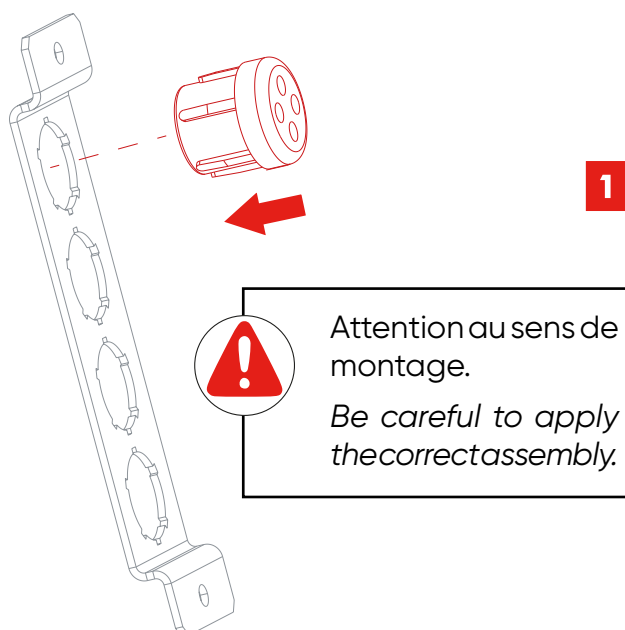

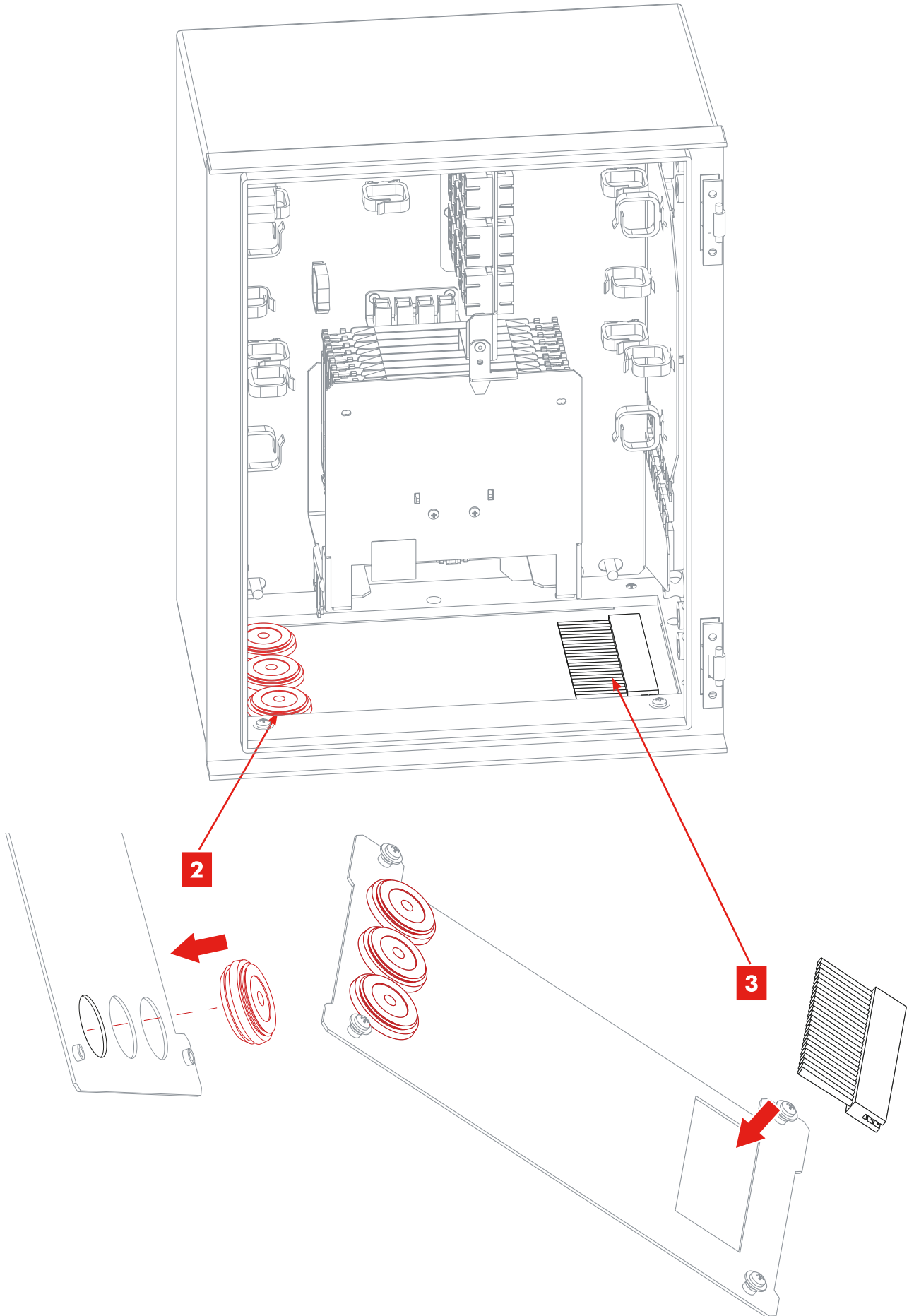

## 3.5. Préparation des cassettes *Preparation of the cassettes*

- |   |  |
|---|--|
| <ol style="list-style-type: none"> <li>1. Enlever couvercle de la cassette</li> <li>2. Détacher les volets de la cassette et les clipser à chaque entrée</li> <li>3. Mettre en place les peignes fournis dans le kit</li> </ol> | <ol style="list-style-type: none"> <li>1. Remove the cover of the cassette</li> <li>2. Remove the shutters of the cassette and clip the mat each entry</li> <li>3. Installation the combs provided in the kit</li> </ol> |
|---|--|

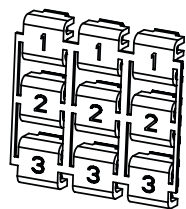
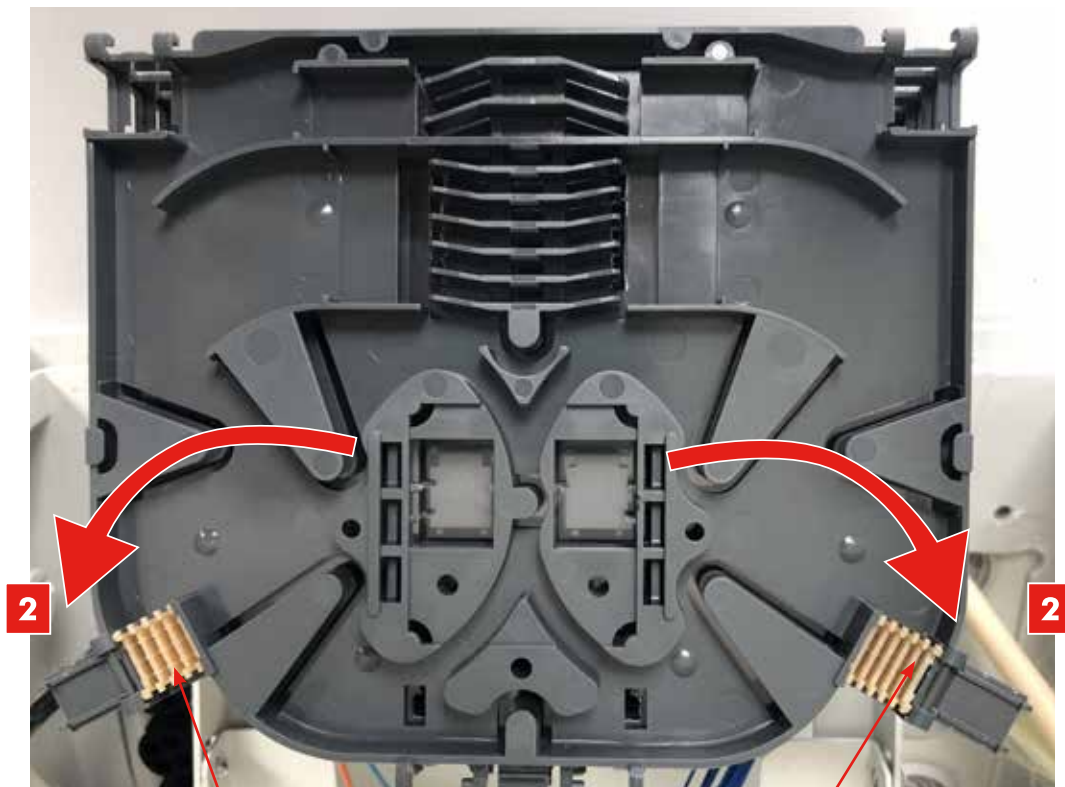

**3**

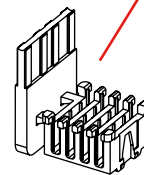

Ou  
Or





## 4. CÂBLAGE CÔTÉ ENTRÉE DU RÉSEAU WIRING ON THE INPUT SIDE NETWORK

### 4.1. Zone de raccordement réseau Network connecting area

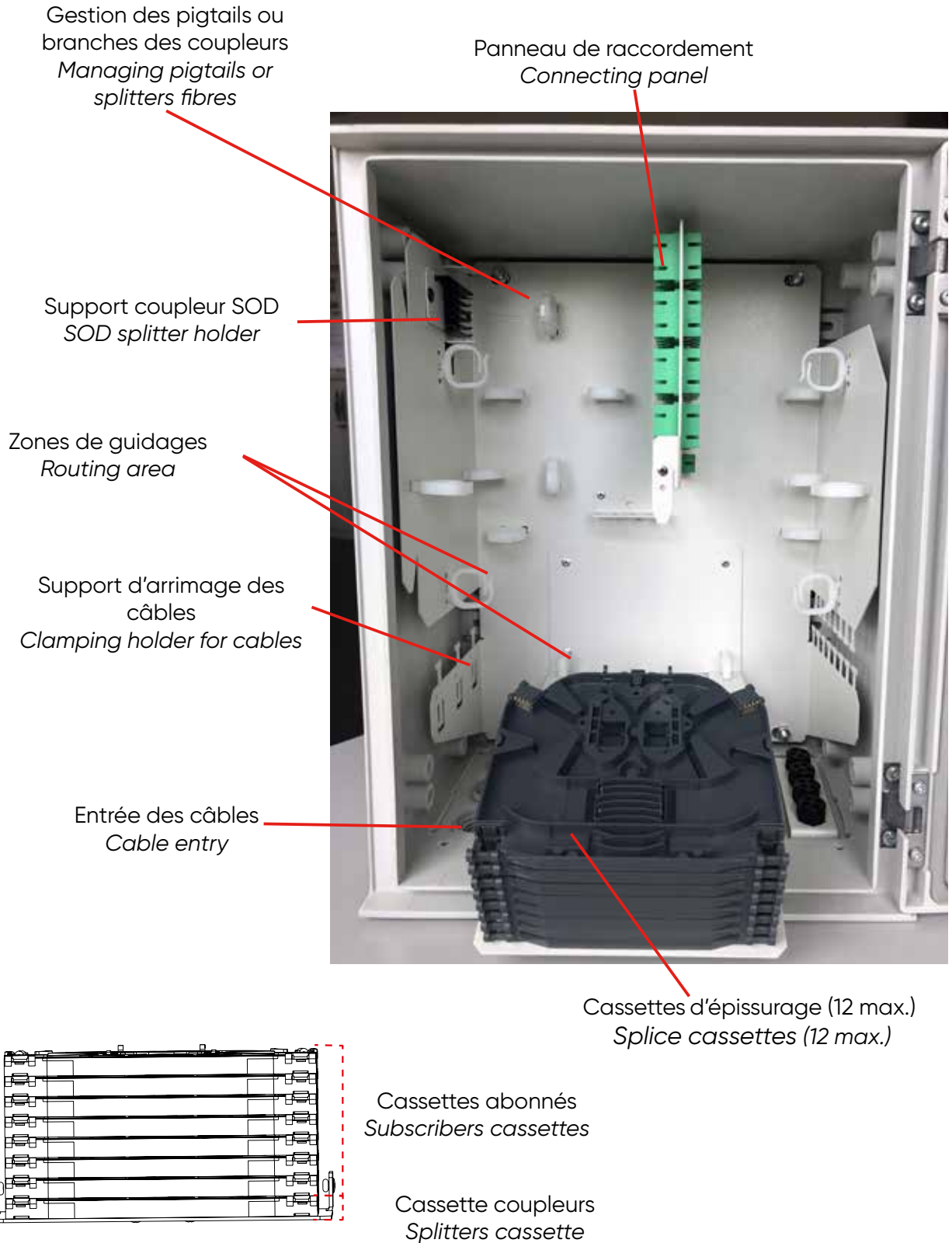



## 4.2. Installation du câble réseau *Installation of the network cable*

- |   |  |
|---|--|
| 1. Préparer le passe câble                              | 1. <i>Preparation of the plug</i>                              |
| 2. Enfiler le câble dans l'embout                       | 2. <i>Put the cable in the grommet</i>                         |
| 3. Préparation du câble réseau                          | 3. <i>Preparation of the network cable</i>                     |
| 4. Mettre les colliers plastique                        | 4. <i>Put the plastic ties</i>                                 |
| 5. Lovage des micromodules jusqu'à la cassette coupleur | 5. <i>Coiling the microbundles up to the splitter cassette</i> |
| 6. Lovage des fibres nues dans la cassette coupleur     | 6. <i>Coiling bare fibres in the splitter cassette</i>         |
| 7. Mise en place du coupleur SOD                        | 7. <i>Installation of the SOD splitter</i>                     |
| 8. Épissage du tronc et/ou des pigtails                 | 8. <i>Splicing the input and/or the pigtails</i>               |

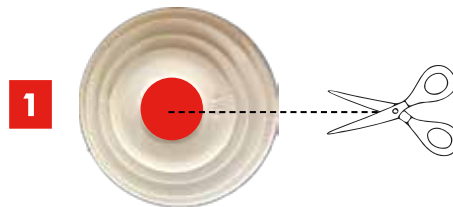

### 3 Préparation du câble *Preparation of the cable*

- |   |   |
|---|---|
| A. Dénuder la gaine du câble sur une longueur de 2200mm | A. <i>Strip the cable sheath on a length 2200mm</i> |
| B. Couper le porteur sur 50mm                           | B. <i>Cut the strength member on a 50mm</i>         |
| C. Couper les aramides sur 100mm                        | C. <i>Cut the aramid on 100mm</i>                   |

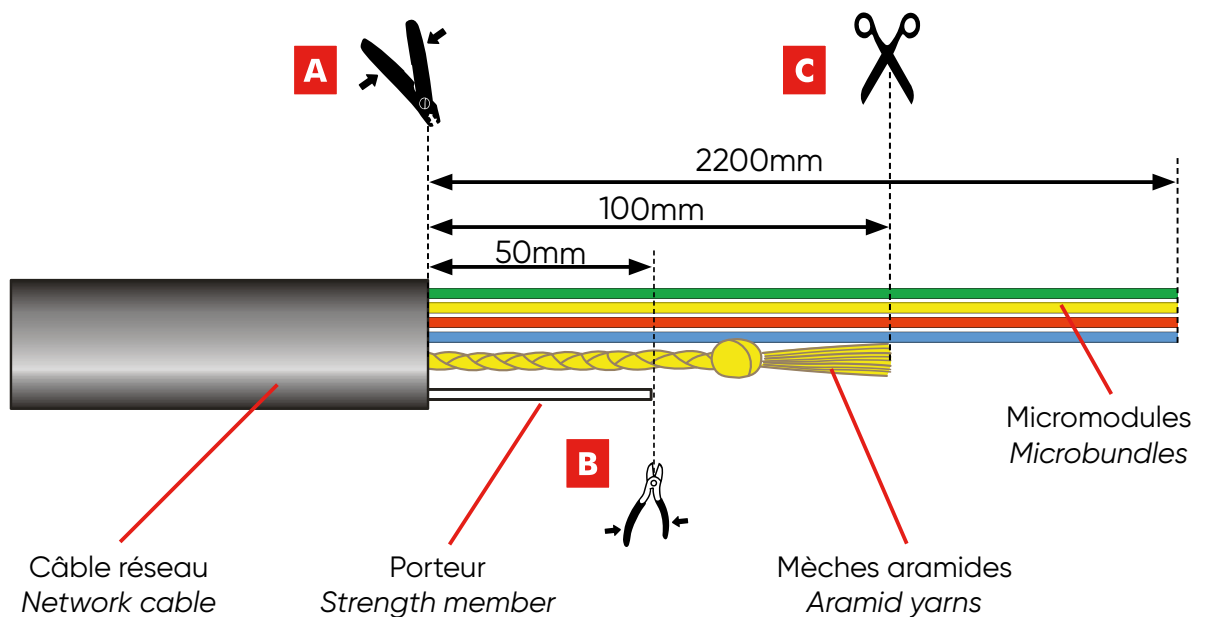

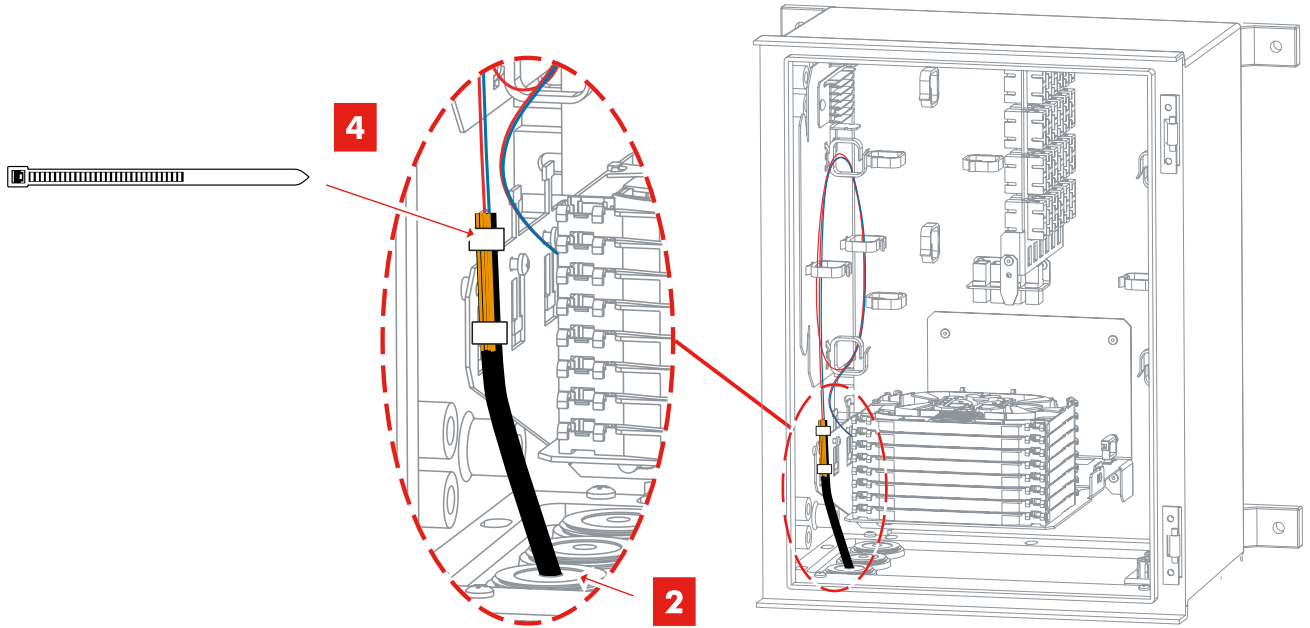

**7** Mise en place du coupleur SOD  
*Installation of the SOD splitter*

- A. Placement du coupleur dans le support
- B. Lovage des branches
- C. Raccordement des branches
- D. Lovage et raccordement du tronc

- A. *Fixing the splitter in the holder*
- B. *Coiling the outputs*
- C. *Connecting the outputs*
- D. *Coiling and connecting the input*

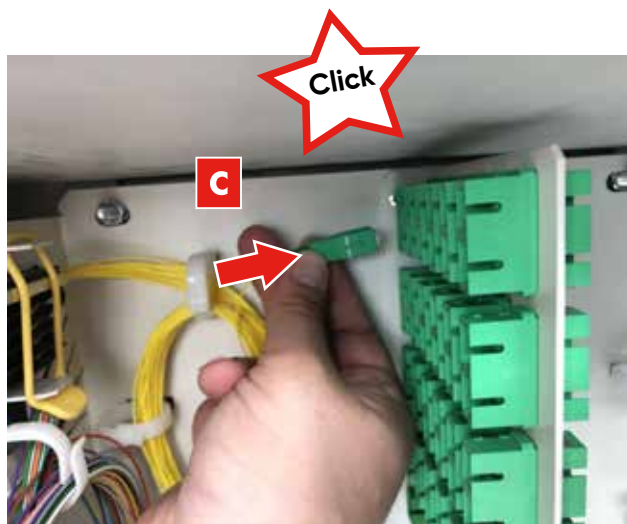

Centrer le coupleur afin de respecter le rayon de courbure des branches.

*Center the splitter to respect the radius of curvature of the outputs.*



**8** Épissurage du tronc et/ou des pigtails  
*Splicing the input and/or the pigtails*

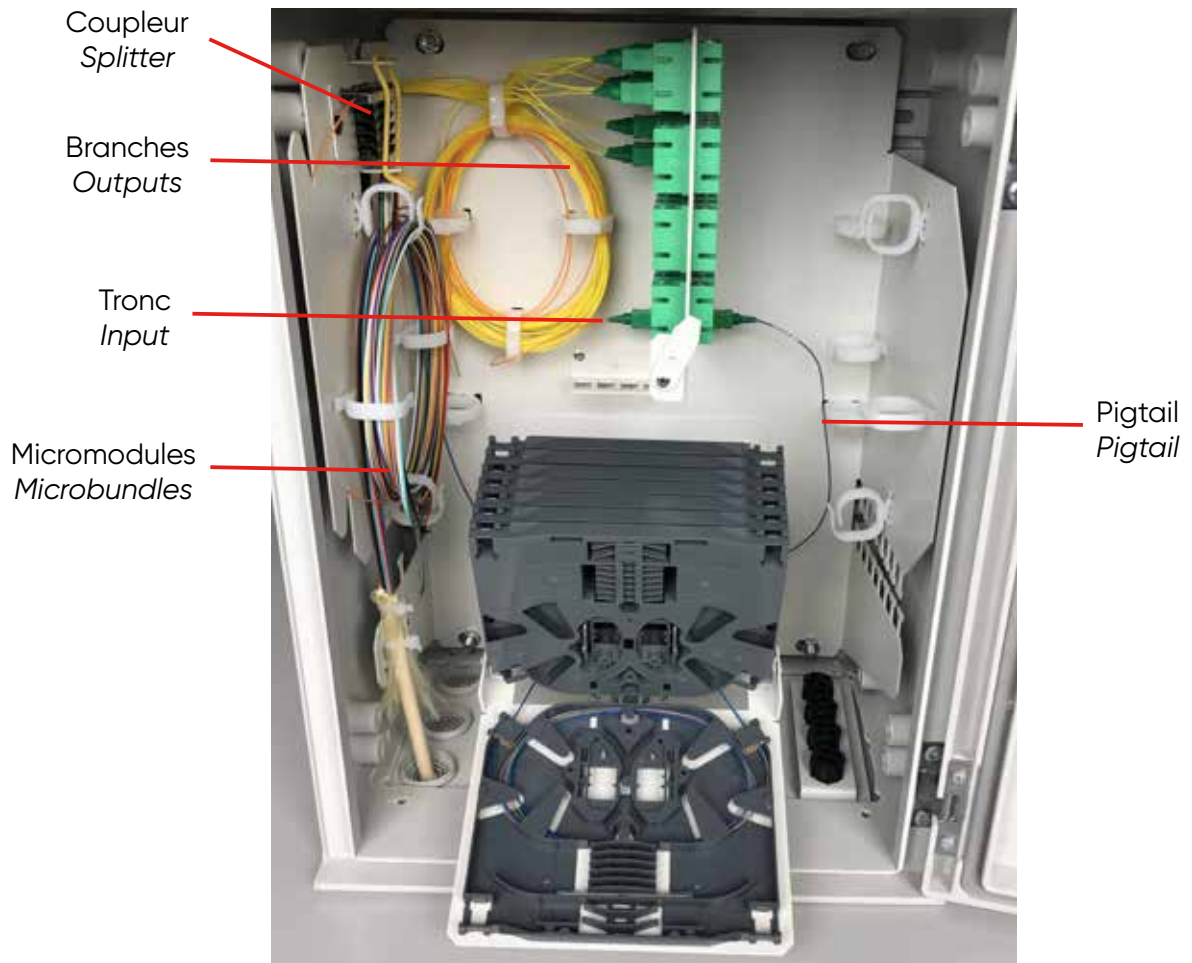

Si le tronc n'est pas préconnectorisé l'épissurage se fera dans la cassette coupleurs.

*If the input isn't preterminated, the splicing will be done on the splitters cassette.*

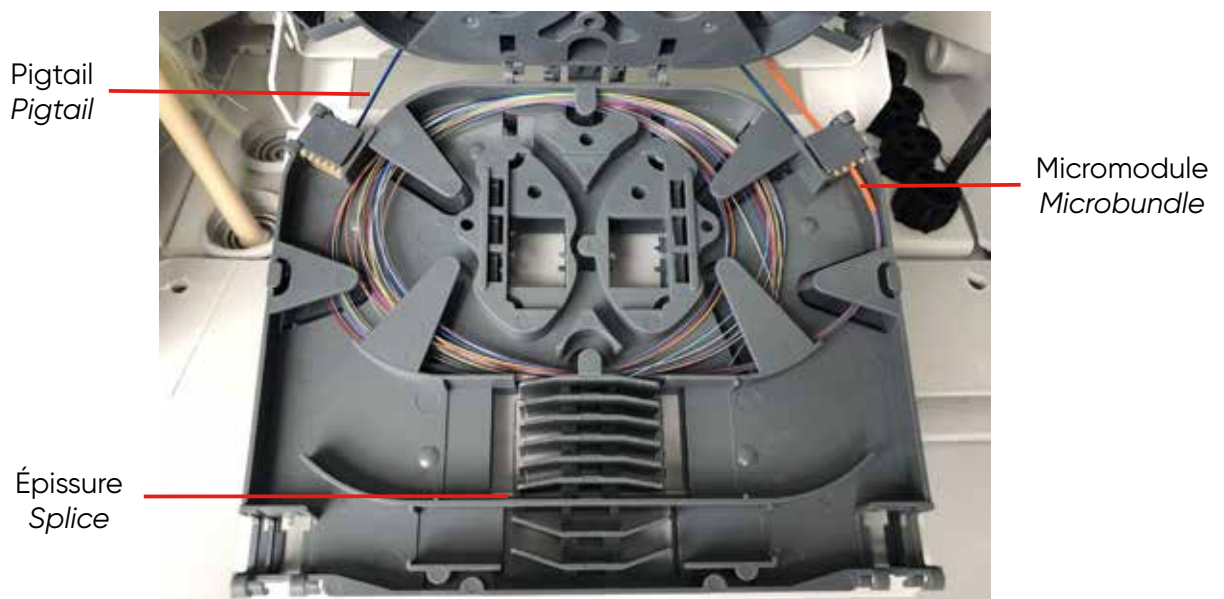

## 5. RACCORDEMENT DES ABONNÉS *CONNECTING THE SUBSCRIBERS*

### 5.1. Zone de raccordement abonnés *Susbscribers connecting area*

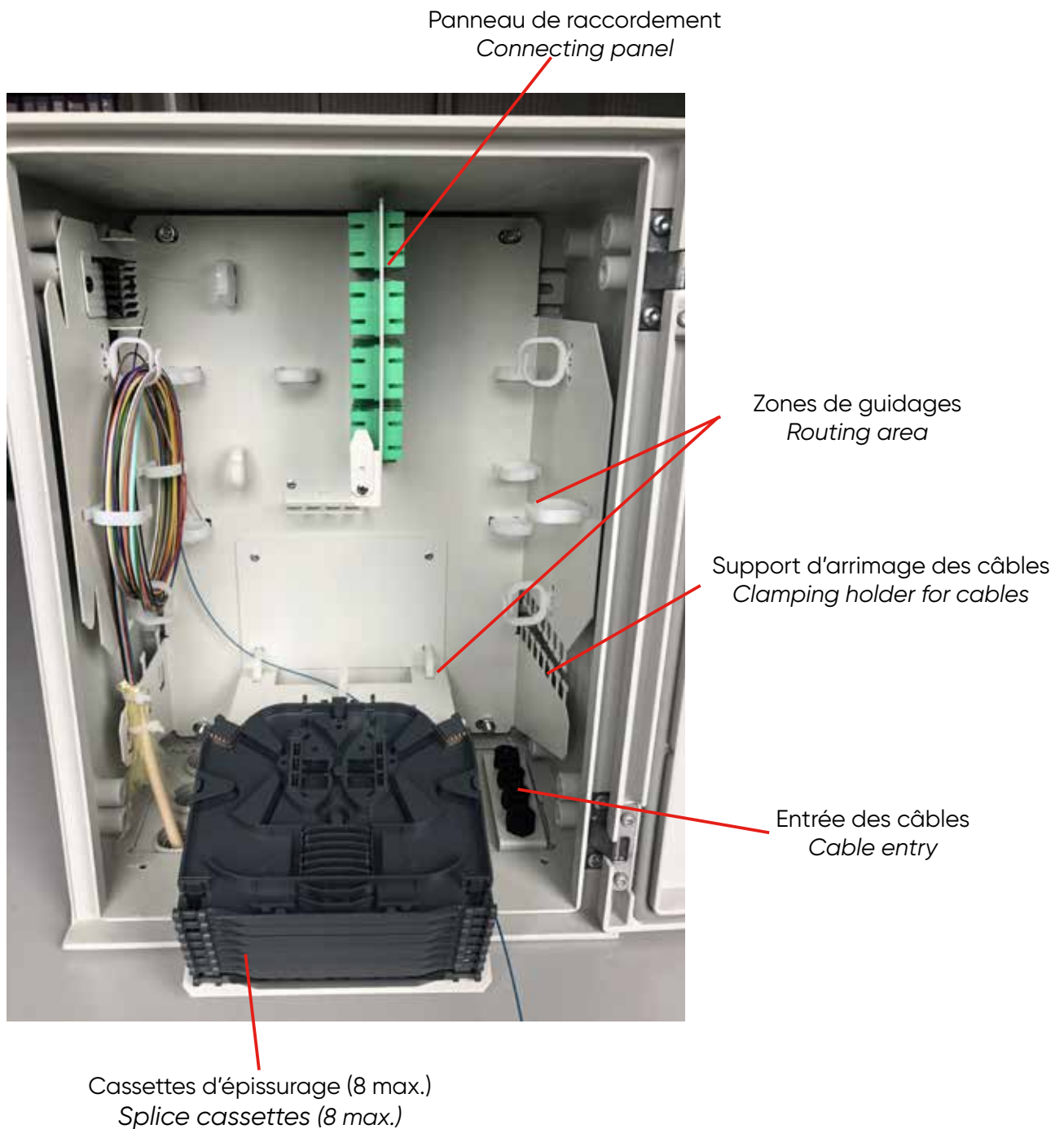

## 5.2. Installation du câble abonnés *Installation of the suscriber cable*

- |  |  |
|--|--|
| 1. Enfiler le câble dans le l'embout                     | 1. <i>Put the cable in the grommet</i>                       |
| 2. Préparation du câble abonnés                          | 2. <i>Preparation of the suscribers cable</i>                |
| 3. Mettre les colliers plastique                         | 3. <i>Put the plastic ties</i>                               |
| 4. Lovage des 900µm jusqu'à la 2 <sup>ème</sup> cassette | 4. <i>Coiling the 900µm up o the 2<sup>nd</sup> cassette</i> |
| 5. Lovage des fibres nues dans la cassette               | 5. <i>Coiling bare fibres in the cassette</i>                |
| 6. Mise en place des pigtails                            | 6. <i>Installation of the pigtails</i>                       |
| 7. Épissage des pigtails et du câble abonnés             | 7. <i>Splicing pigtails and suscribers cable</i>             |

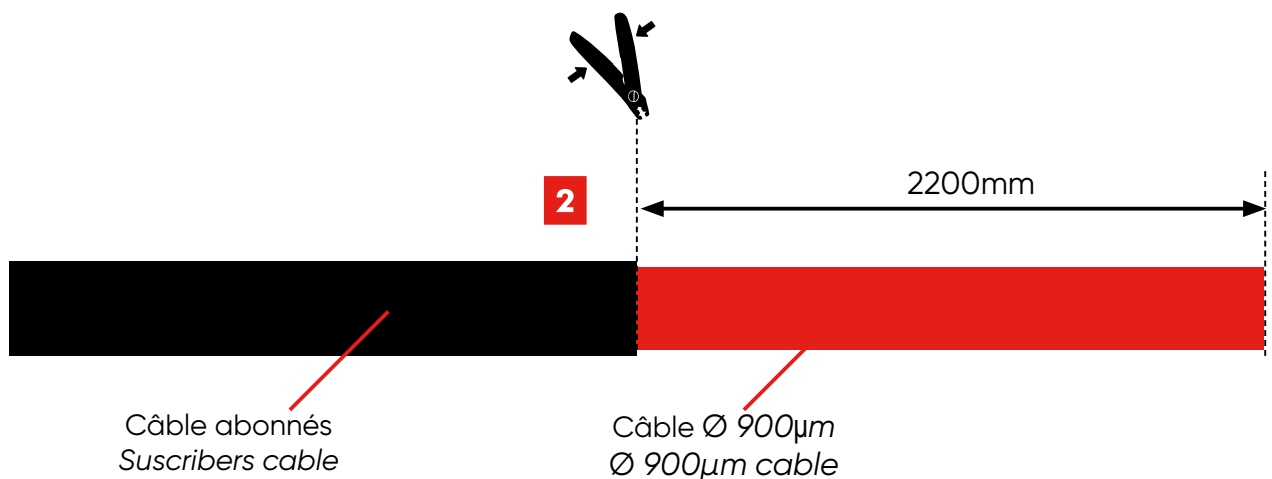
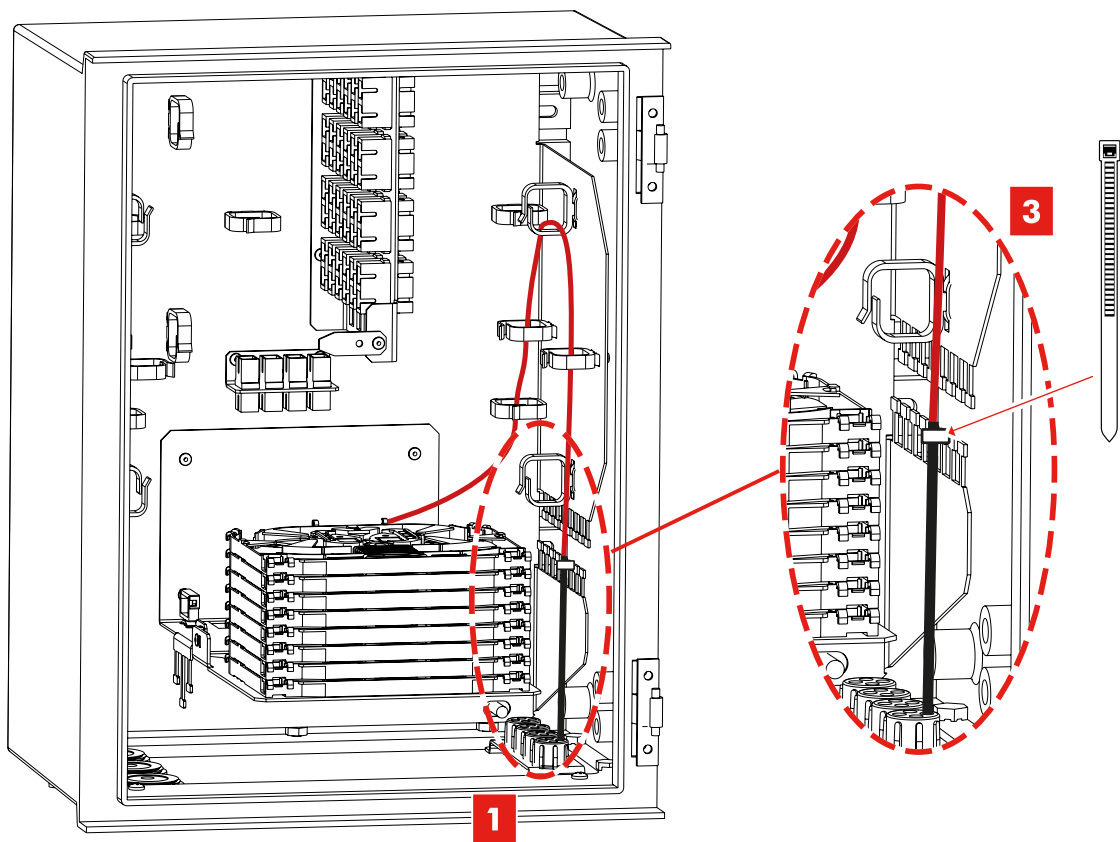



**6** Mise en place des pigtails  
*Installation of the pigtails*

- A. Connection des pigtails
- B. Acheminement jusqu'à la cassette

- A. Connection of pigtails
- B. Routing up to the cassette

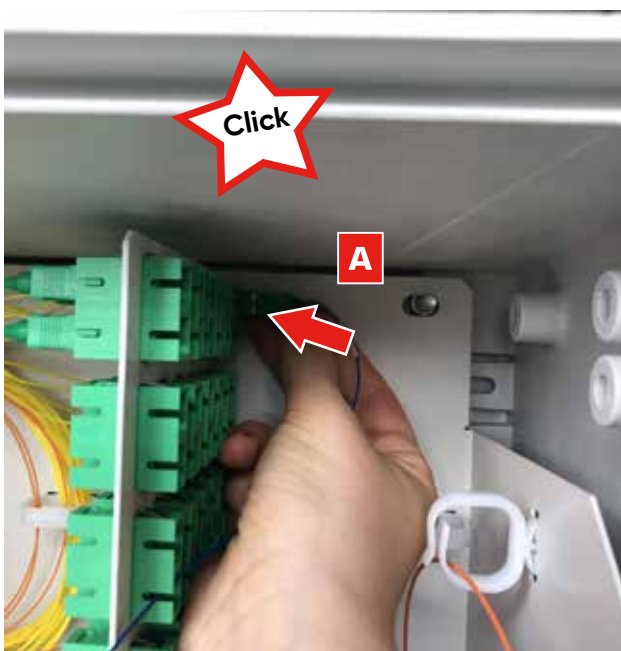



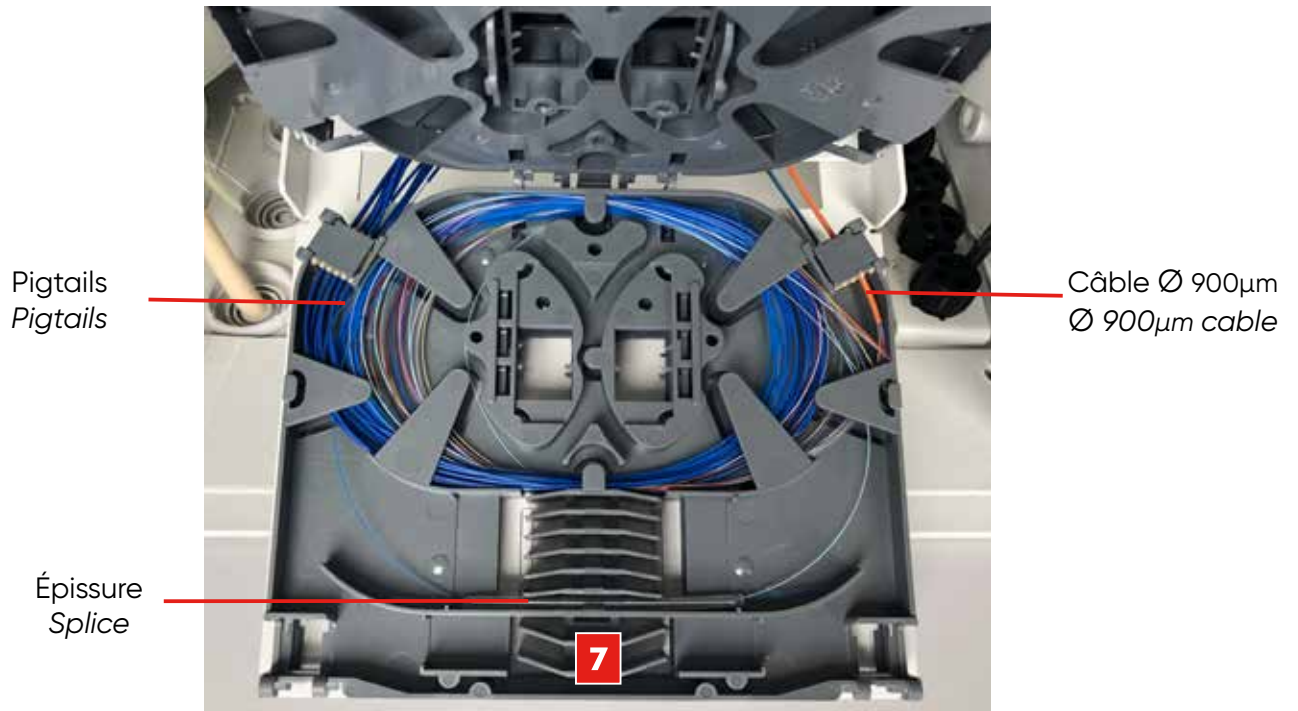

**6. FERMETURE DU BOÎTIER**  
**CLOSING THE BOX**

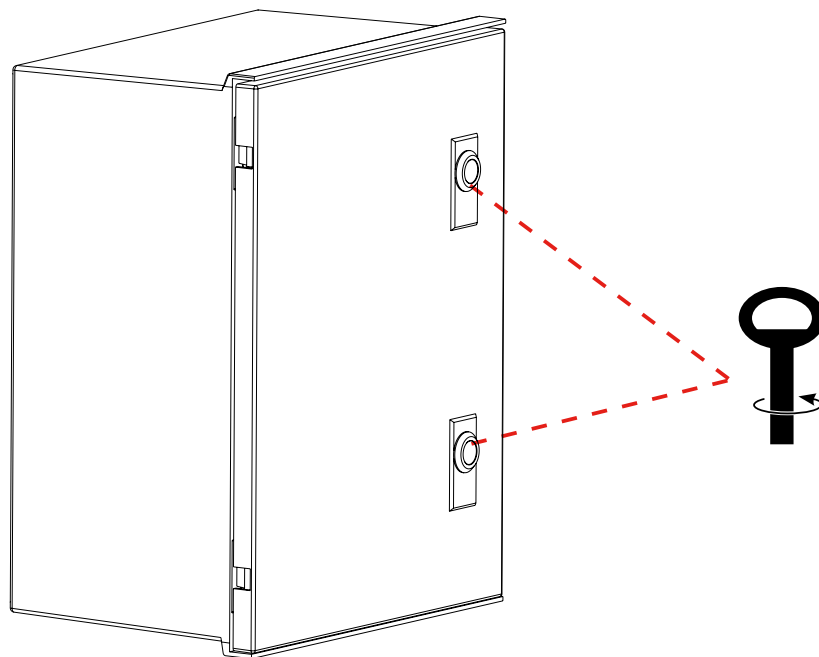



7. INSTRUCTIONS DE FIN DE VIE  
END LIFE INSTRUCTIONS

	 <p>Emballage carton, sachet plastique <i>Cardboard, plastic packaging</i></p>	 <p>Sachet zip réutilisable <i>Reusable zip bag</i></p>
 <p>Pièce métallique et plastique <i>Metal and plastic component</i></p>	<p><b>WEEE / DEEE</b></p>  <p>Équipement électrique et électronique <i>Electrical and electronic equipment</i></p>	

Se connecter via LinkedIn  
Connect via LinkedIn



En savoir plus sur Youtube  
Learn more on YouTube

Visiter [www.aginode.net](http://www.aginode.net)  
Visit [www.aginode.net](http://www.aginode.net)

Contactez-nous via  
Contact us via  
[info@aginode.net](mailto:info@aginode.net)

AGINODE  
25, avenue Jean Jaurès  
08330 Vrigne-aux-Bois  
FRANCE  
Tel. +33 (0) 3 24 52 61 61